

ATWOOD & MORRILL®

ENGINEERED ISOLATION & CHECK VALVES



ATWOOD & MORRILL®

Engineered Isolation & Check Valves

BATLEY VALVE®

High Performance Butterfly Valves

RED POINT®

Tailor-Made Valves

BLAKEBOROUGH®

Control, Choke & Steam Conditioning Valves

HOPKINSONS®

Isolation Valves

SARASIN-RSBD®

Safety & Safety Relief Valves

SEBIM®

Nuclear Pilot Operated Safety Valves

TRICENTRIC®

Triple Offset Butterfly Valves



QUALITY ASSURANCE

Trillium Valves USA™, operates quality programs to cover the full scope of their activities. Comprehensive quality systems have been developed to serve the power, oil & gas and industrial markets which they serve.

The company holds approvals to:

ISO 9001:2015

ISO 14001:2015

Pressure Equipment Directive 97/23/EC Module H

ASME Section III 'N' and 'NPT'

Nuclear Utility Procurement Issues Committee (NUPIC)

The company is committed to compliance with legislation and holds a certificate to OSHAS 18001 for Environmental Health and Safety.

An ongoing commitment to customer care is met through the process of continuous improvement and the further development of our systems and processes toward meeting ISO 9001:2015.

VALVE TESTING FACILITIES

All pressure containing items are hydrostatically tested, seat leakage tested and functionally tested. In addition, gas, packing emission, cryogenic and advanced functional testing can be arranged.

MATERIAL TESTING FACILITIES

- Non-destructive examination by radiography, ultrasonics, magnetic particle and liquid penetrant
- Chemical analysis by computer controlled direct reading emission spectrometer
- Mechanical testing for tensile properties at ambient and elevated temperatures, bend and hardness testing. Charpy testing at ambient, elevated and sub-zero temperatures

For more technical information, visit our website at www.trilliumflow.com

CONTENTS

Introduction	1 – 2
Massachusetts	3
FREE FLOW® Reverse Current Valve	4 – 9
Cold Reheat Check Valves	10 – 12
Compressor Check Valves	13 – 15
Positive Closing Check Valves	16 – 19
HP Swing Check Valve Wye	20 – 21
Globe Valves	22 – 24
3-Way Valves	25 – 27
Parallel Slide Gate Valves	
Class 600 - 2500 Class	28 – 31
1000, 1700, 2500	32 – 34
Forged Gate	35 – 38
Carbon & Alloy Steel	39 – 41
Equalizing Devices	42 – 43
Vee Port	44
Reheat Isolation Device	45
Atmospheric Relief Valve	46 – 48
Spring Relief Valves	49
Service & Replacement Parts	50 – 52
Valve Product Offering	53
Notes	54 – 57

ABOUT TRILLIUM VALVES USA™

Trillium Valves USA™, is an innovator in the design and manufacture of engineered valves. Founded in 1900 as Atwood & Morrill Co. Inc., the company has developed an impressive range of high technology valves and gained a distinguished reputation for product integrity, performance and dependability.

Trillium Valves USA™ is a business unit of Trillium Flow Technologies™ owned by First Reserve, a private equity company founded in 1984. Trillium employs 2,300 people worldwide.

The company began operations when Charles Atwood and Herbert Morrill entered into a partnership in the valve repair business. In the early 1900's, they started to manufacture condensate traps and single seat, piston type reducing valves. The product offering grew with the development of products for steam lines such as steam traps, regulators, back pressure valves and check valves for use in New England mill operations. Atwood & Morrill was incorporated in 1922 in the state of Massachusetts. In 1929, the company introduced its Free Flow® Reverse Current Valve for turbine extraction applications. The modern version continues to be the power industry standard for turbine protection globally.

In the 1940's, A&M supported the U.S. war effort by developing damage control (flooding), magazine sprinkling and other safety valve systems for the United States Navy. This relationship with the U.S. Navy led to A&M's involvement in the nuclear power business, when the company designed and manufactured the first reactor coolant pump check valves for the first naval prototype nuclear reactor at the National Reactor Test Station near Arco, Idaho. In 1954, A&M valves, including the main reactor coolant pump check valves, were onboard the Navy's first nuclear powered submarine.

A&M continued to evolve throughout the 1950s, 60s and 70s to meet the growing needs of the traditional fossil fuel and new nuclear power plants. Trillium was recognized as one of the first valve suppliers to receive the ASME N-Stamp accreditation under both the Atwood & Morrill® and Hopkinsons® names.

In the 1980s, A&M began selling the Hopkinsons U.K. designed Parallel Slide Gate Valve to the U.S. market. This valve is installed where feedwater, main steam and hot/cold reheat isolation are necessary.

The Tricentric® product line was acquired in 1995. Tricentric®, a unique sealing butterfly valve, has process, commercial power and nuclear applications. Its metal seat is inherently fire safe.



In 2008, the company consolidated its Salem, Massachusetts operations in an expanded facility in Ipswich, MA. This facility holds our N and NPT Stamp certifications.

Atwood & Morrill® and Tricentric® valves are used in Coal Fired Plants, Combined Cycle Gas Plants, Simple Cycle Plants, Cogeneration Plants, Geothermal Plants, Biomass Fueled Plants and Nuclear Boiling Water Reactors and Pressurized Water Reactors. Industrial valves are installed in plants in the Process, Petrochem, Refinery, Steel and Pulp & Paper industries.

We understand that our customer responsibility does not end with the sale. Our companywide commitment to LEAN principles assures efficient and rapid response to customer needs.

Behind each valve we sell stands capable Spare Parts and Field Service departments, working closely with Engineering and Manufacturing groups to assure total product satisfaction. Comprehensive instruction manuals and customer training schools provide classroom and shop training for installation and maintenance knowledge.

In our 120 year history, we have built our reputation and success on the development of new technology, with uncompromising standards of design excellence and product quality. Every valve that carries the A&M name meets these strict standards.

Atwood & Morrill®, Free Flow® Reverse Current Valve and Tricentric® are trademarks of Trillium Valves USA™.

PHYSICAL PLANT AREA

Indoors: 106,525 square feet
Outdoors: 336,160 square feet

WAREHOUSE

Indoors: 35,000 square feet

WELDING EQUIPMENT WITH ASME CODE QUALIFIED WELDERS

Processes include:

Shielded Metal Arc
 Gas Tungsten Arc
 Gas Metal Arc
 Plasma Arc

QUALITY ASSURANCE EQUIPMENT & CERTIFIED NONDESTRUCTIVE EXAMINATION LEVEL III PERSONNEL

In Radiography, Liquid Penetrant, Magnetic Particle and Ultrasonic

PRESSURE AND LEAK TIGHTNESS EQUIPMENT

High Pressure: MSIV, 40 inch + Valves to 10,000 psi
Medium Pressure: Check Valves, 1,500 to 10,000 psi
Low Pressure: Valves, 150 to 1,000 psi

QUALITY PROGRAMS

Quality Policy Manual – ISO 9001
Quality Assurance Manual – Nuclear (10 CFR 50 Appendix B)
 Quality Assurance Manual Adjunct (CMS) – Nuclear Safety Related Program

SHIPPING FACILITIES

Truck: From Plant in Ipswich, Massachusetts
Air: From Boston, Massachusetts (25 miles)
Ocean: From Boston, Massachusetts (25 miles)
 From New York, New York (240 miles)



Manufacturing plant in Ipswich, MA



DESCRIPTION

Atwood & Morrill® Free Flow® Reverse Current Valves are designed to give maximum protection to extraction steam turbines. Their rapid, tight closure ensures that the high level of energy found in feedwater heaters or process lines is quickly isolated from the turbine in the event of a load rejection.

The power cylinder is designed to give a strong closing moment to the valve when signaled to do so by plant instrumentation. A lost motion feature allows the valve disc to close independently of the power cylinder.

APPLICATIONS

- Turbine Non-Return
- Extraction Steam Non-Return
- Bleeder Trip Valve
- Bled Steam Non-Return Valve

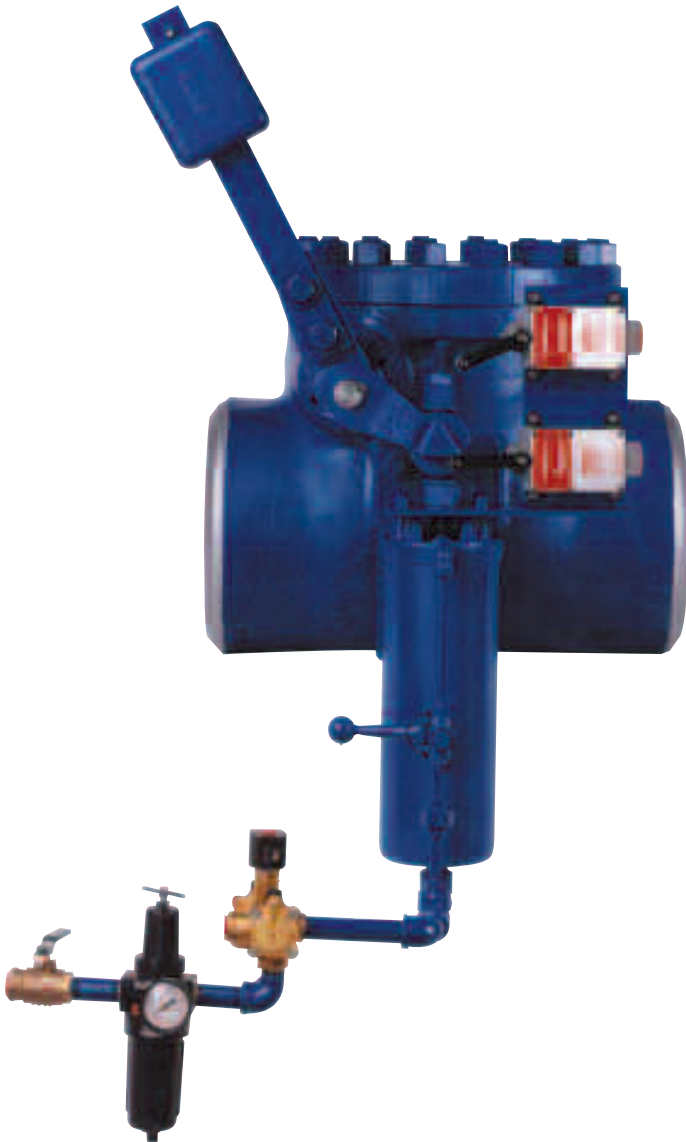

SPECIFICATIONS

Design Standard:	ASME B16.34 and applicable international specifications as required
Pressure Classes:	ASME 150-1500
Sizes:	Cast construction 3"-48"
Materials:	Carbon steel, alloy steel and stainless steel per ASTM specifications or applicable international standards
Trim:	Stainless steel ASTM A479 Type 410
Seats:	Stainless steel overlay or hardfacing alloy
Bonnet Design:	Bolted bonnet with nonasbestos gasket
End Connections:	Butt weld or flange end
Power Cylinder:	Pneumatic or hydraulic
Drain Connections:	As required
Limit Switches:	1, 2, or 3 SPDT or DPDT switches available
Cylinder Valves:	Solenoid operated air valves or pilot operated oil relay valves
Exerciser Valves:	Optional solenoid or manual valves available
Special Features:	<ul style="list-style-type: none"> • Low friction stuffing boxes • Nondestructive examination as required by customer specification or ASME B16.34 Special Class
Installation:	Horizontal or vertical upflow as specified

DESIGN FEATURES

The important role of a Non-Return Valve as a protective device demands a high level of reliability. The features found in all Atwood & Morrill® Free Flow® Current Valves assure that reliability. These features, along with a high grade of workmanship and materials, assure a superior and completely dependable valve.

Free Swinging Disc

(Fig. 1a) Trillium Valves USA™ utilizes a basic swinging disc Check Valve design. This uncomplicated design provides independent movement of the disc in the flow stream with fast closure upon loss or reversal of flow. The valve disc is of sturdy construction to prevent distortion under full design pressure.

Inclined Seat Design

(Fig. 1b) The Atwood & Morrill® Free Flow® Reverse Current Valve has an inclined seat to improve the performance and operating characteristics of the valve. This design offers advantages not available with other seat configurations.

The inclined seat combined with flat disc and body seat contact provides the best configuration available in Check Valve design.

An opening angle of 75° from the vertical or 45° from the inclined seat results in low pressure drop.

The reduced swing arc also enables the valve to close quickly. Full opening with a vertical seat would require a greater swing arc and a longer closing time.

The center of gravity of the disc assembly causes a positive seating moment, therefore, the weight of the disc is always acting to seat it and hold it firmly against its seat. A portion of the disc weight can be counterbalanced in larger valves to reduce pressure drop at low flows, so the flow is not required to raise the full weight of the disc.

The Atwood & Morrill® inclined seat design features - POSITIVE, TIGHT SEATING - FAST CLOSURE - LOW PRESSURE DROP - all important Check Valve considerations.

Self Aligning Disc and Disc Arm

(Fig. 2) The disc and disc arm assembly are self aligning with the seat, assuring tight sealing. An internal stop provides the proper degree of disc opening while maintaining the edge of the disc within the flow stream, so that flow reversal will cause closure.

(Fig. 3) The valve disc is provided with an anti-rotation device that prevents the disc from rotating on the disc arm. This feature is critical in eliminating wear on the disc post that could result in separation of the disc from the disc arm.

Figure 1a

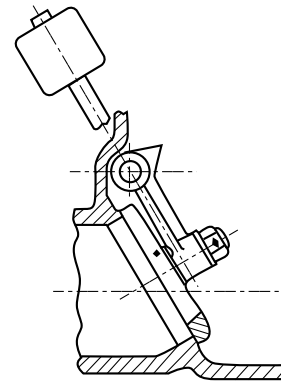

Figure 1b

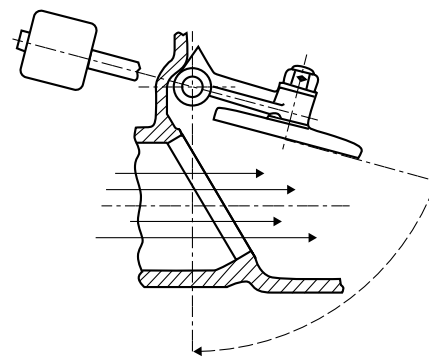

Figure 2

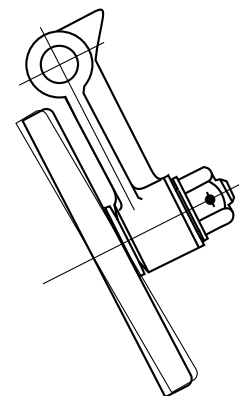
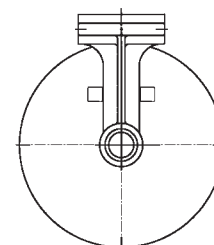

Figure 3



DESIGN FEATURES

Shaft and Bushing Assembly

(Fig. 4) Large diameter stainless steel shafts together with hardened stainless steel bushings are used on all A&M Free Flow® Reverse Current Valves. The results are lower stresses, less wear and longer life.

Positive Closing

The powerful spring in the power cylinder assures rapid positive closing before reverse flow can occur.

Balanced Shaft Construction - Internal Lost Motion Device

(Fig. 5) INTERNAL BALANCE DESIGN

An “internally balanced” design is standard on all 12" and smaller valves equipped with a closure assisting cylinder. This feature eliminates stuffing box friction and shaft end thrust which might prevent free swinging of the valve disc.

With this design the disc assembly is not connected to the shaft by a key, allowing it to swing independent of shaft rotation. Instead the linkage to the air cylinder is internal to the valve by a mating part to the disc assembly called a “shaft dog”, which is attached to the shaft by means of a key.

When the air cylinder is energized the shaft rotates the shaft dog open and its mating face disengages from the disc assembly allowing it to react to flow as in a conventional swing check valve. Upon de-energizing the side air cylinder the shaft rotates the shaft dog closed and its mating face engages the disc assembly applying a closing force to it.

Valve Body & Bonnet

The A&M design employs a streamlined body contour for minimum flow resistance. Heavy body wall thickness assures rigidity and resistance to pipe strain distortion. A bolted top cover is provided for ease of access to valve internals, thus the valve need not be removed from the line for maintenance and inspections.

External Lever

Larger size valves are supplied with a counter weight to reduce pressure drop at low flows to maintain full disc opening and reduce disc slamming.

Cylinder Operated

(Fig. 6) Spring loaded positive closing air cylinders can be provided on all Free Flow® Reverse Current Valves. Oil operated cylinders are also available. Oil cylinders may be ordered with an optional oil relay valve. Both types can be exercised by a lever operated Test Valve or Solenoid Valve.

Figure 4

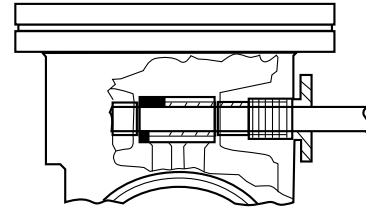

Figure 5

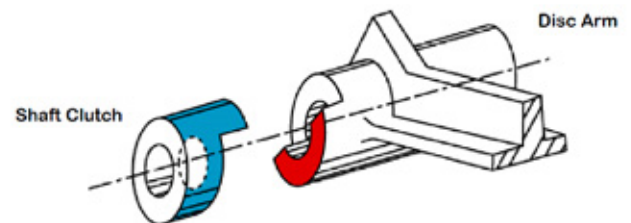
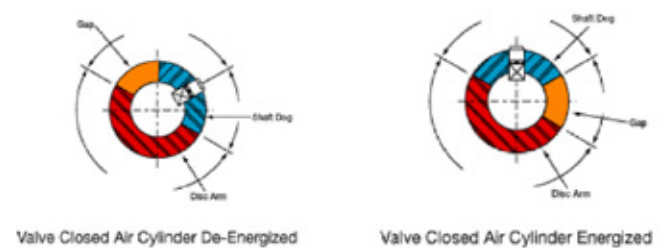
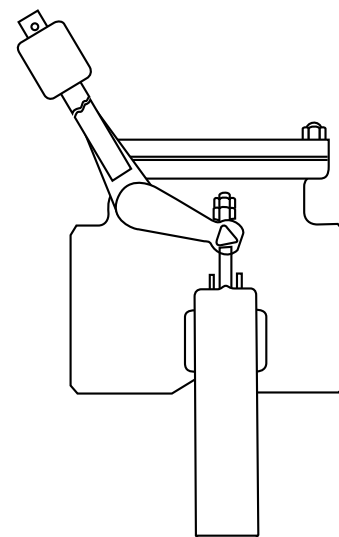

Figure 6



APPLICATIONS FOR TURBINE EXTRACTION SYSTEMS

Air Operated Systems

Figure 7 shows an A&M Air Operated Free Flow® Reverse Current Valve operated by turbine overspeed trip and high water level in the feedwater heater.

The oil operated Air Relay Dump valve (normally supplied by the turbine manufacturer) translates oil pressure from the turbine overspeed trip system into air pressure. With oil pressure established, compressed air flows through the Air Relay Dump Valve with the atmospheric vent closed. Upon loss of oil pressure due to turbine overspeed trip, incoming air pressure is closed off, and the atmospheric vent is opened to release air pressure from the Check Valve cylinder. This action allows the spring force to assist in closing the Free Flow® Reverse Current Valve. IT IS IMPORTANT THAT THE SOLENOID OPERATED 3-WAY VALVE USED ALLOWS FLOW IN THE REVERSE DIRECTION.

The Solenoid Operated 3-Way Valve is installed in the air supply line to the cylinder. Upon receipt (or loss) of an electrical signal from the heater high water level alarm, the Solenoid Valve trips, closing the air supply and opening the vent to atmosphere.

Air is exhausted from the air cylinder, and the spring starts to close the valve.

The lever operated Air Test Valve equalizes pressure on both sides of the cylinder piston so that the spring force moves the piston downward and exercises the valve during operation.

The system shown in Figure 8 differs from Figure 7 as the oil operated Air Relay Dump Valve is replaced by an oil pressure switch which converts the loss of oil pressure due to a turbine overspeed trip to an electrical signal. This signal is connected to the solenoid valve in series with the heater high water level alarm circuit and trips the solenoid operated 3- Way Valve as in Figure 7.

The quick exhaust valve shown in Figure 8 senses a loss of pressure at its inlet and will shift allowing the air cylinder to exhaust more rapidly through its vent port. This valve can be used in any control system and is recommended whenever a solenoid valve with a low Cv factor is used.

Local exercising of the Free Flow® Reverse Current Valve can also be accomplished by actuating an integral test switch on the solenoid operated 3-Way Valve. Using this method for exercising, the solenoid valve is exercised as well as the Free Flow® Reverse Current Valve.

Combinations of control systems shown in Figures 7 and 8 can also be used.

Control for Turbine Extraction Systems

Figure 7

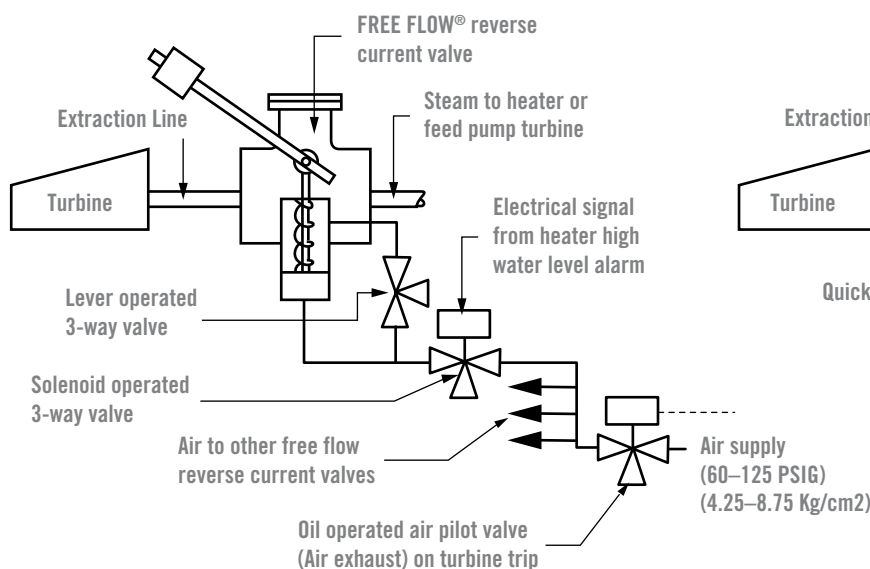

Figure 8

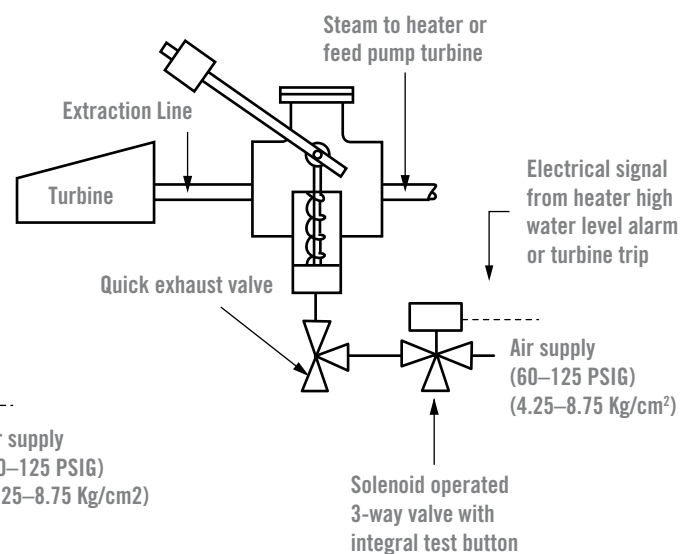

TABLE OF DIMENSIONS

CLASS 150 - 300

SIZE LBS.	A	B	C	D	E	F	G	H	J	K	L	M	N	WEIGHT	CV
4	13.00	7.75	12.88	9.75	6.75	-	-	-	12.06	15.13	3.88	8.81	18.75	300	737
6	14.00	7.75	10.75	9.00	6.75	-	-	-	12.06	15.13	3.88	7.75	18.75	300	870
8	21.00	11.75	16.50	15.00	7.00	-	-	-	14.25	17.13	.69	11.75	15.50	650	2500
10	22.75	11.00	15.50	16.00	9.00	-	-	-	14.75	17.63	.88	10.25	14.00	700	3180
12	24.75	11.50	15.50	17.88	9.31	-	-	-	15.81	18.63	.94	10.50	14.00	730	4810
14	24.00	12.13	16.75	19.50	11.38	18.00	16.00	24.50	16.63	19.50	1.88	10.00	13.00	1100	6300
16	26.00	14.00	19.25	21.75	11.25	19.50	17.13	26.25	17.88	20.75	2.38	13.88	19.31	1900	8940
18	29.00	15.50	21.50	25.00	13.25	21.50	17.00	26.00	19.63	22.50	3.69	14.50	18.00	2100	10720
20	31.00	17.38	23.00	26.25	16.00	24.50	20.88	31.75	22.63	25.50	5.19	15.00	16.50	3100	13650
24	37.00	19.50	24.75	30.00	16.00	24.50	27.00	42.00	22.63	25.50	6.50	16.00	15.19	3700	17050
26	37.00	19.50	24.75	30.00	16.00	24.50	27.00	42.00	22.63	25.50	6.50	16.00	15.19	3700	17050
28	46.00	23.50	28.75	34.00	27.50	28.00	24.25	34.25	23.88	26.75	8.25	17.38	13.50	4000	25120
30	50.00	25.00	28.25	37.25	29.00	29.00	23.13	30.75	24.25	27.13	8.25	18.00	13.50	5200	32600
32	50.00	25.00	28.25	37.25	29.00	29.00	23.13	30.75	24.25	27.13	8.25	18.00	13.50	5200	32600
34	53.00	26.50	34.38	40.00	32.13	31.25	28.00	40.13	26.63	29.50	12.13	17.69	9.56	5800	-
36	53.00	26.50	34.38	40.00	32.13	31.25	28.00	40.13	26.63	29.50	12.13	17.75	9.69	6100	40120
42	66.00	33.00	45.00	49.00	35.38	34.75	41.63	64.25	29.88	32.75	17.50	21.50	4.19	14250	58320
44	66.00	33.00	45.00	49.00	35.38	34.75	41.63	64.25	29.88	32.75	17.50	21.50	4.69	15500	58320

NOTE: All dimensions in inches

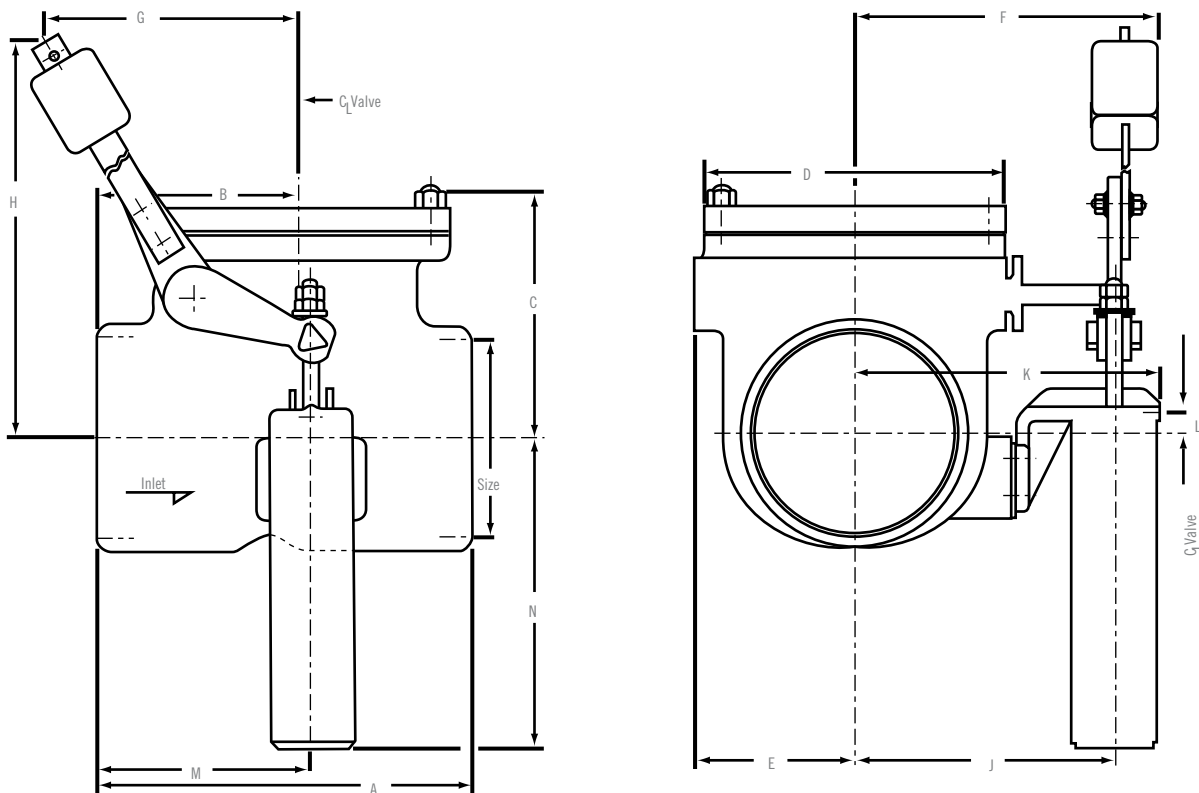

TABLE OF DIMENSIONS

CLASS 400 - 600

SIZE	A	B	C	D	E	F	G	H	J	K	L	M	N	WEIGHT LBS.	CV
4	14	7.75	10.75	10	6.19	-	-	-	9.75	12.75	3.88	7.75	18.5	300	510
6	17.50	9.00	15.88	13.75	7.75	-	-	-	13.00	15.88	3.88	10.13	18.5	500	1294
8	21	11.5	16.5	15	9.25	-	-	-	14.13	17.13	0.25	11.75	14.63	650	2500
10	22.75	12	21.50	19.00	10.25	-	-	-	14.5	17.38	1.5	10.69	13.38	1150	4025
12	24.75	12.75	19.88	21.5	10.00	-	-	-	15.88	18.75	1.88	10.63	13	1470	5960

CLASS 900

SIZE	A	B	C	D	E	F	G	H	J	K	L	M	N	WEIGHT LBS.	CV
8	21	11.5	20.00	18	10.38	-	-	-	15.13	18	0.25	11.75	14.63	800	2500
10	22.75	12	21.50	19	10.25	-	-	-	14.5	17.38	1.5	10.69	13.38	1150	4025
12	24.75	13	21.63	22.25	12.25	-	-	-	16.50	19.38	1.88	11.69	13.38	1700	5960

NOTE: All dimensions in inches

END TO END DIMENSIONS FOR VALVES WITH FLANGES

SIZE (IN.)	CLASS 150	CLASS 300	SIZE (IN.)	CLASS 150	CLASS 300
4	16	16	14	28	29 1/2
6	16	16 7/8	16	30	31 5/8
8	18	19	18	33	35
10	22	23 3/8	20	36	37 5/8
12	24	25 1/2	24	44	45 3/4

Consult factory for other sizes. Flanged ends per ASME B16.5

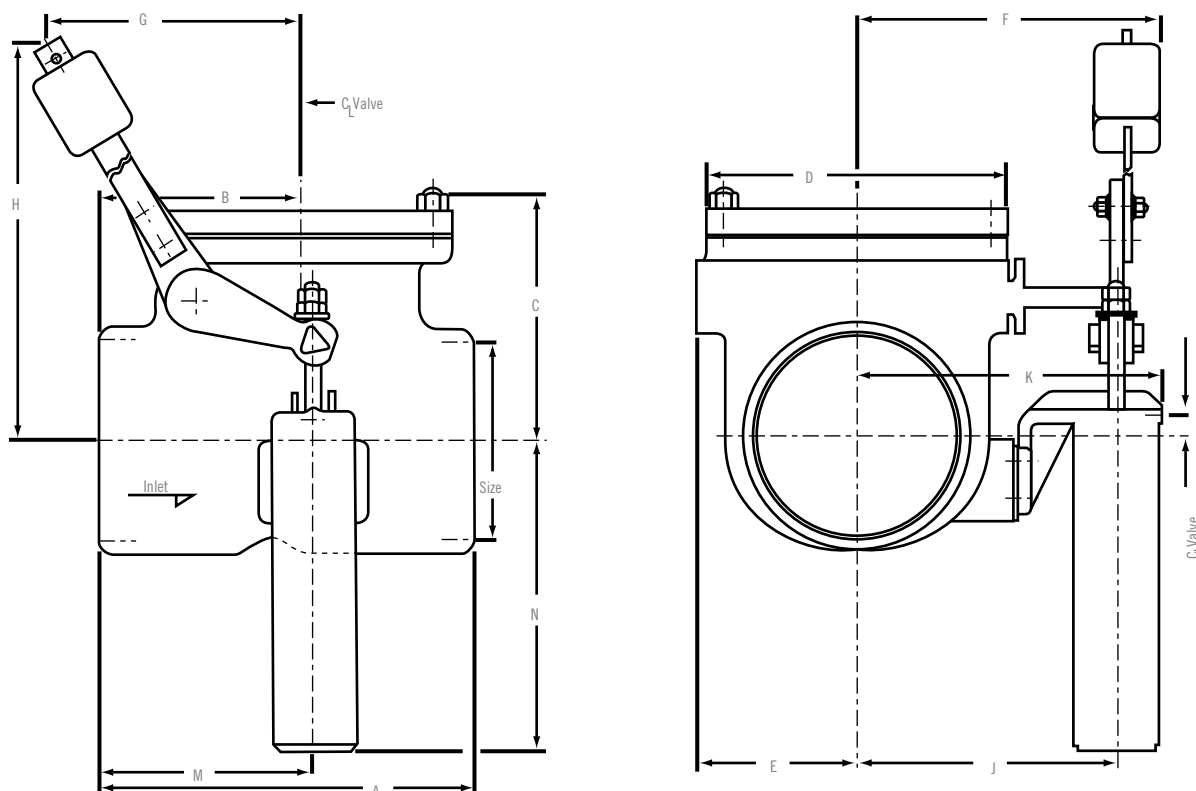

The Atwood & Morrill® Cold Reheat Check is a reliable, sturdy valve that protects the High Pressure (HP) Steam Turbine from damage caused by reverse flow during unit trip.

In newer Rankine and Combined Cycle plants, the Cold Reheat Check Valve must also accommodate the increased demands of a Turbine Bypass System and isolate the HP Turbine Exhaust when the bypass is in use.

APPLICATIONS

Rankine and Combined Cycle Power Plants with Reheat

Prevents Reheat Steam from Returning to Turbine on Trip
Simplifies Hydrotesting of the Reheater.

Protects the High Pressure Turbine Exhaust from Bypass Steam and Water when the Turbine Bypass system operates.

Isolates High Pressure turbine exhaust when auxiliary steam is supplied to the IP turbine in a combined cycle unit, to synchronize the steam turbine generator or start the gas turbine on a single shaft machine.

FEATURES

Proven, Swinging Disc Design
Wide, Flat, Non-jamming Seats for Tight Seal
Air Cylinder

- Standard closure assist
- Special dual configuration

Smooth Flow Passages for Low Pressure Drop
In Line Maintenance through Bolted Top Cover
Inclined Seat for Short Travel & Quick Operation
Rugged Construction
Ability to Withstand Multiple Rapid Closures

OPERATION

During normal operation, the Atwood & Morrill® Cold Reheat Check is open to forward flow. It becomes a critical, quick closing valve which protects the turbine during trips or equipment failure.



42" Class 600 Cold Reheat Check

DEMANDS

Quick Acting, Turbine Bypass Systems rapidly change pressure and flow in the reheat piping, requiring the Cold Reheat Check valve to close quickly.

The frequent Start ups and Shutdowns of Cycling Units may require the Cold Reheat Check valve to operate several times per day.

Very Tight Sealing is necessary to prevent steam and water from entering the HP turbine.

Low Pressure Drop is important to overall combined cycle unit performance.

Available Sizes: 16" to 48" and ASME Classes 300 to 600

Materials: Carbon and Alloy Steels

SIZING AND SELECTION

Proper sizing requires verification of flow conditions. Ideally the disc should be in the Full Open Position, Not Chattering or Fluttering in Flow Stream. This allows for Low Wear and Low Pressure Drop.

The counterweight must be properly sized to allow optimum operating conditions and full open disc.

BLOWDOWN COVERS FOR COLD REHEAT CHECK VALVES

The Atwood & Morrill® Blowdown Cover allows cleanout/blowdown of the pipeline to be easily and efficiently done. The simple design bolts on in place of the valve’s existing cover and provides an easy blowdown connection. An optional blowdown disc can also be supplied when large amounts of damaging debris are anticipated.

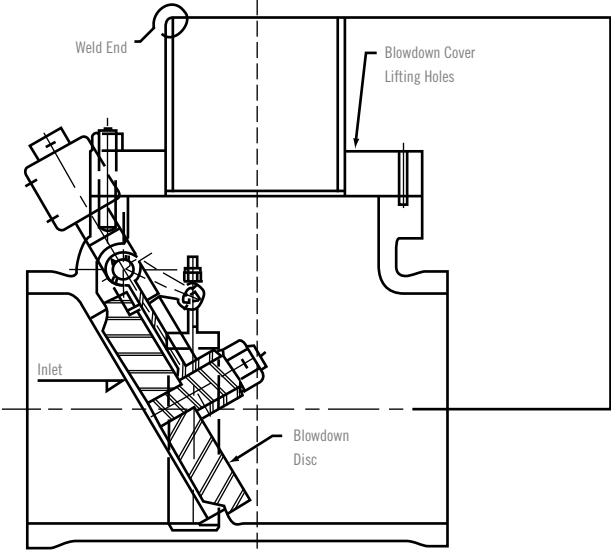

CONSTRUCTION

The fabricated blowdown cover has a weld end for easy pipe connection and lifting holes for easy removal after blowdown is complete. The optional valve disc is carbon or alloy steel.

OPERATION

After startup and blowdown, the Cold Reheat Check Valve’s standard cover is replaced.

When using Cold Reheat Check Valves consider your blowout requirements carefully. When blow-down is started upstream of the Cold Reheat Check Valve, remove the disc to prevent damage. A seat protector ring is available. When blowdown is required but a cover is not provided, field fabrication can be time consuming. If blowdown is expected to carry a lot of debris, an additional disc may be useful. For help meeting your system’s requirements, contact the sales or service department.

TRILLIUM VALVES USA™ HAS OVER 80 YEARS EXTRACTION AND REHEAT STEAM SERVICE EXPERIENCE.



44" Cold Reheat Check Valves

TABLE OF DIMENSIONS

CLASS 300

SIZE	A	B	C	D	E	F	G	H	J	K	L	M	N	WEIGHT LBS.	CV
18	29.00	15.50	21.50	25.00	13.25	21.50	17.00	25.88	19.63	22.50	3.69	14.50	18.00	2100	10720
20	31.00	17.38	23.00	26.25	14.63	24.50	20.88	31.75	22.63	25.50	5.19	15.00	16.50	3100	13650
24	37.00	19.50	24.75	30.00	12.63	24.50	27.00	42.00	22.63	25.50	6.50	16.00	15.19	3700	17050
26	44.00	22.50	27.00	34.00	-	27.50	24.25	34.00	23.88	26.75	-	16.38	13.50	3850	24120
28	46.00	23.50	28.50	34.00	-	27.50	24.25	34.00	23.88	26.75	-	17.38	13.50	3960	25120
30	50.00	25.00	28.25	36.75	-	29.00	23.13	30.75	24.25	27.13	-	17.94	13.50	5200	29800
32	50.00	25.00	28.25	36.75	-	29.00	23.13	30.75	24.25	27.13	-	17.94	13.50	5200	36200
34	53.00	26.50	34.38	40.00	32.13	31.25	28.00	40.13	26.63	29.50	12.13	17.69	9.56	5800	-
36	53.00	26.50	34.38	40.00	32.13	31.25	28.00	40.13	26.63	29.50	12.13	17.69	9.56	6100	40120
42	66.00	33.00	45.00	49.00	35.38	34.75	41.63	64.25	29.88	32.75	17.50	21.50	4.19	14250	58320
44	66.00	33.00	45.00	49.00	35.38	34.75	41.63	64.25	29.88	32.75	17.50	21.50	4.19	14250	58320

CLASS 600

SIZE	A	B	C	D	E	F	G	H	J	K	L	M	N	WEIGHT LBS.	CV
14	28.00	14.00	21.75	24.00	11.25	19.00	17.13	26.25	17.88	20.75	4.19	13.81	19.31	2100	8050
16	28.00	14.00	21.75	24.00	11.25	19.00	17.13	26.25	17.88	20.75	4.19	13.81	19.31	2100	8470
18	30.00	15.00	25.38	27.00	12.50	22.25	16.88	26.38	19.00	21.88	4.19	14.00	17.56	2750	10780
20	33.00	17.38	29.50	29.25	16.00	25.81	20.88	31.75	22.63	25.50	4.19	16.00	17.56	3100	13460
24	44.00	22.00	38.63	37.00	-	29.25	22.75	34.00	23.75	26.63	9.50	16.50	12.25	7600	19960
26	44.00	22.00	38.63	37.00	-	29.25	22.75	34.00	23.75	26.63	9.50	16.50	12.25	7600	23560
28	50.00	27.13	32.00	37.00	-	29.50	26.00	35.13	24.25	27.13	8.25	19.81	13.50	7800	27500
30	50.00	27.13	32.00	37.00	-	29.50	26.00	35.13	24.25	27.13	8.25	19.81	13.50	7800	32330
32	55.00	27.50	36.50	42.00	-	31.75	32.00	45.50	27.13	30.00	11.00	18.69	10.75	9500	37650
34	55.00	27.50	36.50	42.00	-	31.75	32.00	45.50	27.13	30.00	11.00	18.69	10.75	9500	43425
36	59.00	29.50	43.75	47.50	-	33.50	35.25	50.13	28.50	31.88	13.75	18.31	8.00	15000	49665
38	59.00	29.50	43.75	47.50	-	33.50	35.25	50.13	28.50	31.88	13.75	18.31	8.00	15000	56425
40	66.00	33.00	49.25	52.25	24.13	34.75	34.50	67.00	30.75	33.63	17.00	21.44	4.69	20,000	58,300
42	66.00	33.00	49.25	52.25	24.13	34.75	34.50	67.00	30.75	33.63	17.00	21.44	4.69	20,000	58,300

NOTE: All dimensions in inches

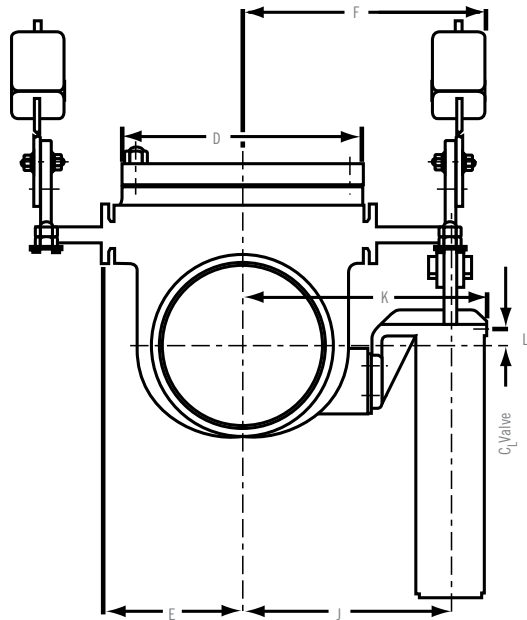
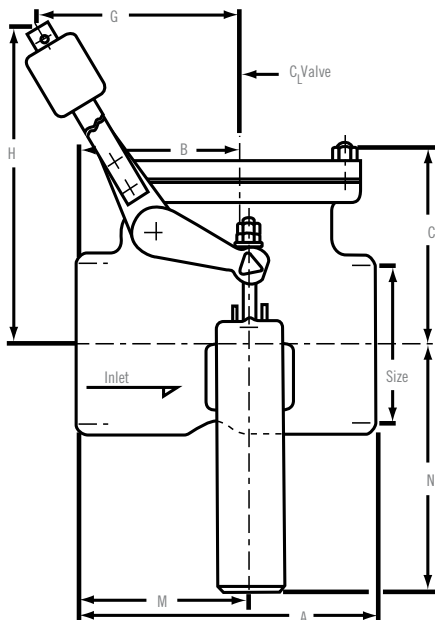

The Atwood & Morrill® Compressor Check Valve is designed to provide positive protection for the blower or compressor. It is installed in the compressor discharge line when specified as:

- Tight sealing pressure
- Low differential pressure
- Power assisted
- Dashpot

APPLICATIONS

Fluid Catalytic Cracking Air Blower Discharge

Compressor Discharge and Process Application

Fluids: Hydrocarbon (Cracked Gas), Ethylene, Propylene, Other Process Fluids

OPERATION/FEATURES

The A&M Compressor Discharge Check Valve is essential in providing protection for critical equipment.

CLOSURE ASSIST AIR CYLINDER

The Compressor Check Valve operates normally with the disc in the open position for long periods. To ensure the check valve will close in the event of a blower/compressor trip, it is furnished with a closure assist air cylinder. Upon loss of power to the drive device of the blower/compressor, a three-way solenoid valve is de-energized. When the solenoid valve is tripped, the side air cylinder is vented allowing the internal spring to apply a closing force to the lever arm which, in turn, rotates the shaft and disc assembly to the closed position.

EXTERNAL COUNTER WEIGHTS

External counter weights help the valve remain in the full open position at normal operating flow. These weights counter balance approximately 50% of the disc closing moment assuring the valve disc will be fully open providing the lowest pressure drop possible. A&M check valves will be fully open at lower flow rates compared to conventional swing or wafer type check valves.

LOW PRESSURE LOSS

Efficient shape, smooth flow passages and the counterbalance system provide low pressure loss and reduced energy consumption.

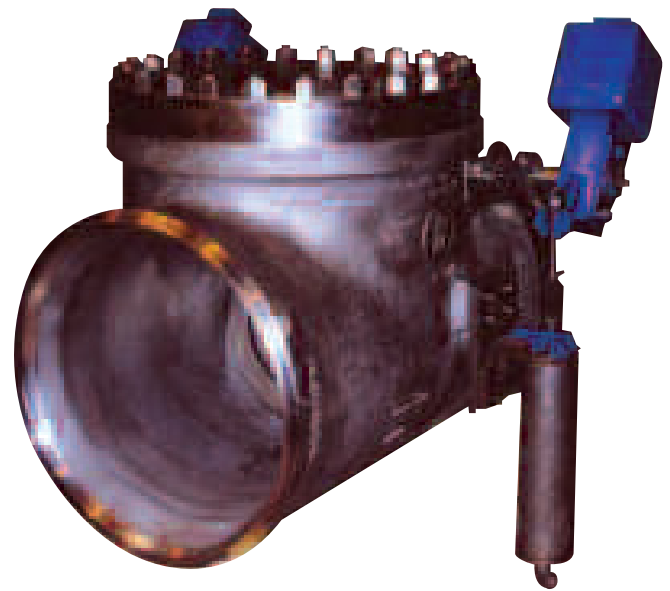

32" Class 300 Compressor
Discharge Check Valve

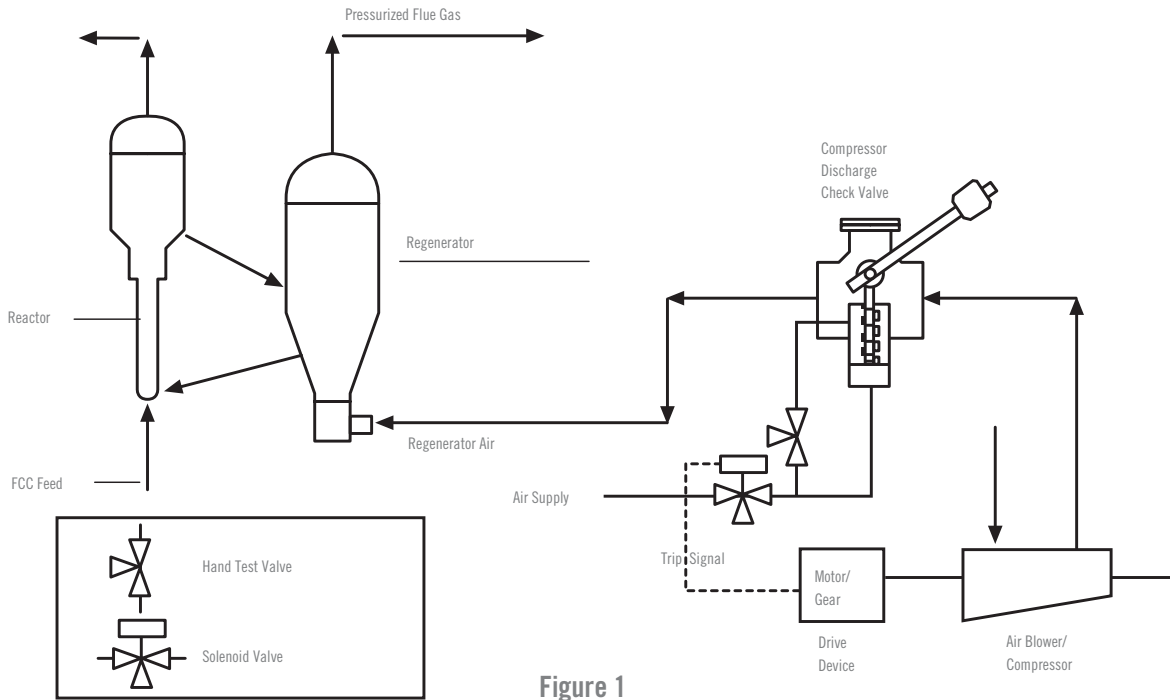
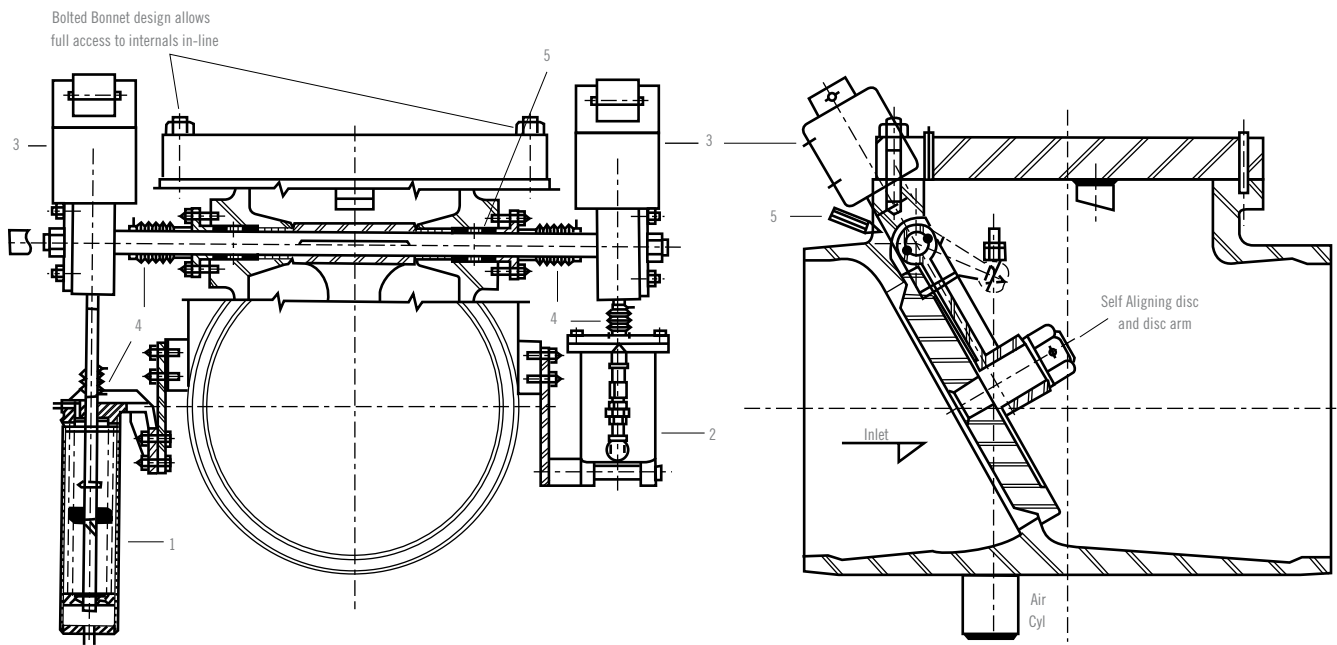

Figure 1

TYPICAL INSTALLATION OF A&M COMPRESSOR DISCHARGE CHECK VALVE IN A FLUID CATALYTIC CRACKING PROCESS UNIT



- 1 -Closure Assist Air Cylinder
- 2 -Oil Dashpot
- 3 -Counterweights act to counterbalance the disc providing the lowest pressure drop
- 4 -Protective Sleeves cover external linkages
- 5 -Lubricated Stuffing Boxes

OIL DASHPOT

Years of experience with blower check valves has indicated that the valve disc will tend to flutter at various flow rates. This constant motion during operation may result in premature packing wear and or valve failure. To prevent this flutter motion, A&M Compressor Check Valves are supplied with an oil dashpot which can be adjusted to dampen the motion and reduce disc slamming.

DEPENDABILITY

Compressor Check Valves are protective devices critical to safeguard the compressor/blower systems. A&M valves are designed to be completely reliable over extended periods of time. Severe damage to the compressor may occur if the disc in a check valve is prevented from closing. The A&M Compressor Check Valve offers positive protection against sticking or hang-up and insures rapid, reliable closing in the event of a trip-out or system shutdown.

MATERIALS

Carbon, Alloy and Stainless Steel

CONSTRUCTION

Design Standard: ASME B16.34



Actual Oil Dashpot



Compressor Check Valve with Oil Dashpot

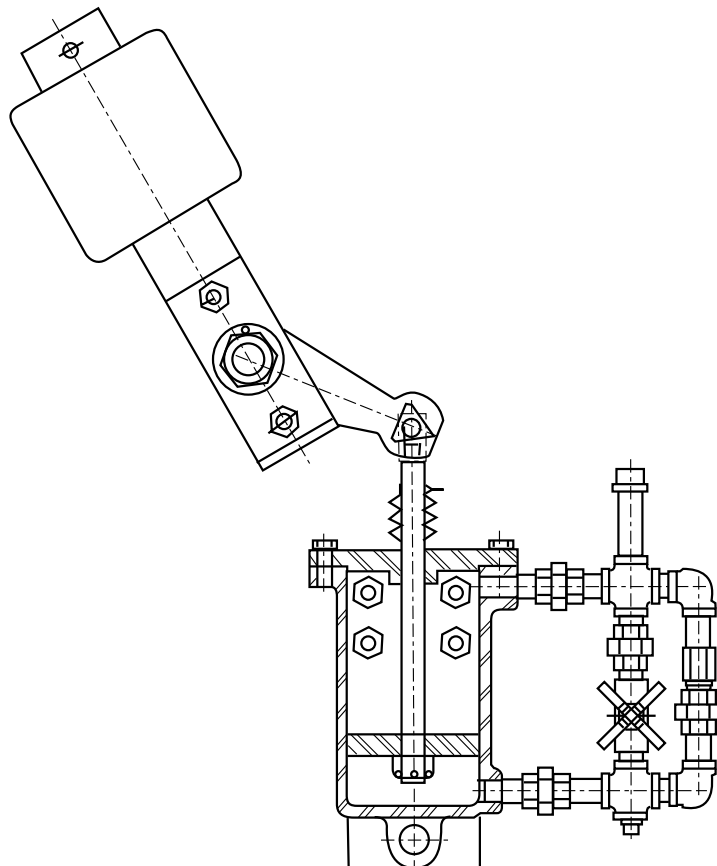

Oil Dashpot

APPLICATION

Atwood & Morrill® Positive Closing Check Valves are used for the discharge lines of boiler feed pumps. These valves provide positive protection for feedwater systems and can prevent damage to costly pumping equipment. Failure to provide such protection could cause serious damage to the feed pumps and their drive mechanisms and may result in a plant outage with a loss of revenues far exceeding the initial investment necessary to provide protective equipment. Figure 1 illustrates the typical use of an A&M Valve with a motor-driven feed pump.

Positive Closing Check Valves can be used to protect pumps that are motor-driven, turbine-driven, or those that are run by drive shaft off the main turbine thereby improving the reliability and dependability of the entire feedwater system. The A&M Valve also offers minimum pressure drop for every day operation.

DESCRIPTION

Atwood & Morrill® Positive Closing Check Valves achieve reliable and rapid closure by means of an auxiliary, spring loaded cylinder, usually actuated by compressed air. The positive closing cylinder acts to close the disc of the valve through a simple engaging mechanism. But, the engaging mechanism does not permit the cylinder to open the valve. In the case of a turbine drive, an Oil Operated Air Relay Valve is used to translate turbine control oil pressure to air pressure. An alternate method is to use a switch, actuated by the turbine trip mechanism, operating a solenoid valve which controls air pressure to the closing cylinder.

FEATURES

Positive, power assisted closure provides fast and reliable protection.

Valve closure before backflow.

“Double protection”; including positive closure and power assisted closure.

Streamlined flow design minimizes pressure drop.

Fast closing minimizes water hammer.

Flat seats for maximum tightness without wedging action.

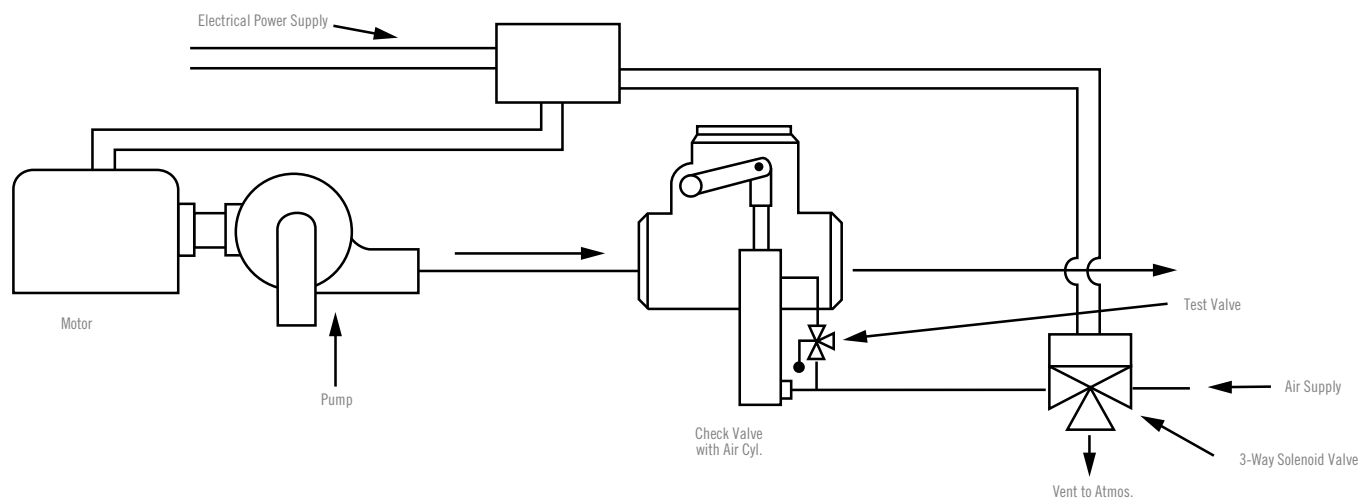
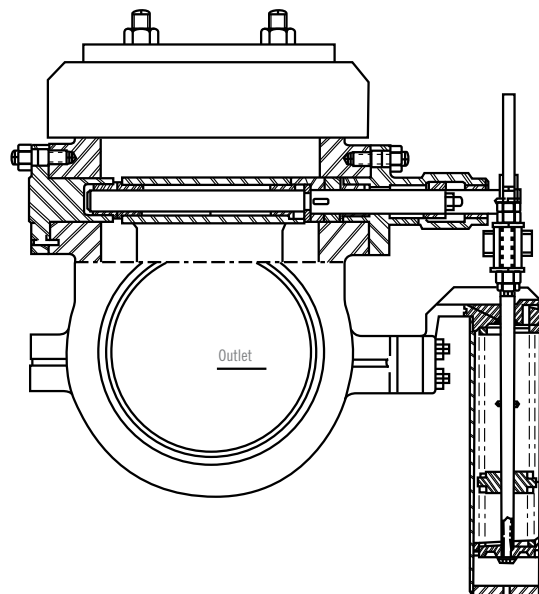

Figure 1

OPERATION

When the piston of the closing cylinder is pushed upward by air pressure, the disc assembly of the valve is free to swing from a closed to a wide open position solely in response to feedwater flow. Disc movement is completely independent of the shaft. A stop on the back of the disc holds it at a slight incline into the flow when the valve is wide open. Normal velocities swing the disc to the full open position and the stop prevents undue flutter or movement.

Cross Section Showing Positive Closing Cylinder & Shaft



WATER HAMMER PROTECTION

High pressure Boiler Feed Pumps operating at high speeds and low inertia can lose speed and stop almost instantaneously, particularly in close coupled systems with short runs of pipe. Should one of these pumps be tripped-out or shut-off, it could go into reverse rotation in a matter of seconds. If reverse flow starts due to the slow closing or failure of a check valve, serious water hammer will result when the valve finally closes. In systems where parallel pumps are used, if one pump is shut down, any surges caused by the working pump will be isolated from the pump which the valve is protecting.

Tests and experience have shown that when an A&M Positive Closing Check Valve is used, water hammer is reduced to a minimum and the pump is assured maximum protection against reverse flow.

Cross Section Showing Inclined Seat & Swinging Disc

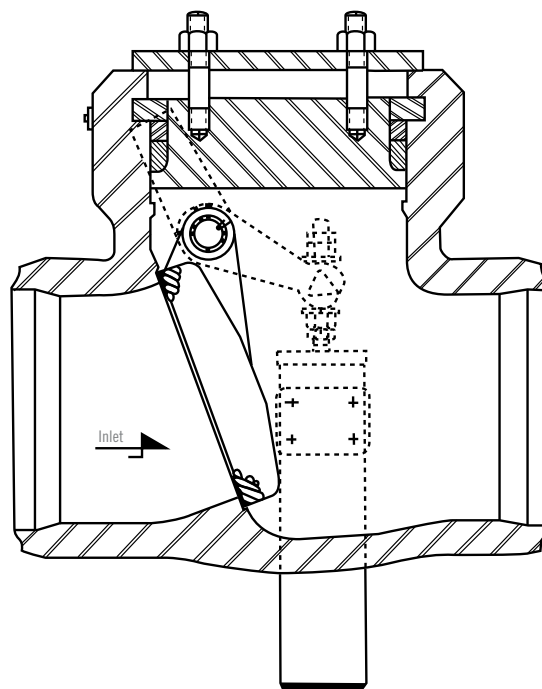

WATER HAMMER TESTS AND RESULTS

Portions of oscillograph tapes of tests made on production line A&M Valves are shown. The tests were conducted by an independent research facility to verify the advantages of fast closing and to demonstrate the effect of positive closing over a swinging disc check valve which was not positive closing. No numerical values are indicated. The following tests were run with the valve in the discharge of a motor driven pump.

- I. A Swinging Disc Check Valve with added weight at the outer edge of the disc, with the valve depending only on gravity for its closing moment.
- II. The same valve as in (I.) above, but with a positive closing cylinder arranged so that air pressure could be released simultaneously with the opening of the electrical circuit of the motor drive.

The trace lines indicate pressure during the test and at the moment of valve closure. The height of the line indicates the magnitude of the water hammer.

A comparison of the tapes shows the almost amazing results obtained when the positive closing cylinder was used. During the series of tests, it was also demonstrated that sluggish or retarded closing would severely increase water hammer, further proving the advantage of fast, positive closing. When summarizing the results of the tests, the laboratory report states:

“This intensity of water hammer (i.e., when positive closing was used) was almost inaudible and with no apparent vibration.”

FEATURES AND DESIGN ADVANTAGES

Dependability and positive closure

Positive Closing Check Valves are protective devices that must be completely reliable over extended periods of time. An average pump is “on stream” for a number of months and flow holds the valve in a wide open position for long intervals. Serious damage may result if foreign matter or sediment accumulates between the shaft and the bushings and retards or prevents free self closure. A&M valves offer positive protection against sticking or hanging-up and insure rapid, reliable closing in the event of a trip-out or shutdown.

Double Protection

Some plants use two simple check valves in series as a means of insuring positive closure. Such double valving may be unnecessary, since a single Atwood & Morrill® valve provides double protection with two methods of closure. First, the A&M Valve acts as a selfclosing Check Valve when air pressure is admitted to the cylinder. Second, it acts as a Power Actuated Valve when air pressure is released from the cylinder on a trip-out.

Minimum Pressure Drop and Full Flow Efficiency

A&M Boiler Feed Pump Check Valves assist in keeping pressure drop in the feedwater piping system at a minimum, particularly when a single A&M Valve replaces a “double valve” installation. The streamlined characteristics of the A&M design make it an efficient valve to use, which is particularly important when long term installed costs are considered.

“Internal Balance”

The A&M Valve is designed so that the disc assembly is “pressure balanced”. This means that the disc assembly is free to swing independently of the operating shaft. The disc is not subject to stuffing box friction or end-thrust tending to force it against the side of the valve. The operating shaft, which passes through the stuffing box is stationary under normal operating conditions. It is rotated only on a trip-out or shut-down by the closing cylinder, which has ample power to overcome stuffing box friction or other causes for sticking. In very high pressure installations, the operating shaft is “pressure balanced” by using double stuffing box construction.

One-Piece Body Construction and Simple Design

A&M Boiler Feed Pump Check Valves are designed with a one-piece body and relatively few moving parts to minimize operating difficulties and simplify maintenance. Once installed, a valve can be inspected easily without removing it from line and the internals can be removed through the top cover. The closing mechanism can also be inspected easily without removing it from the valve by taking off the cylinder to expose the piston. The cylinder and piston assembly can then be examined for wear. If it becomes necessary to remove the piston, the threaded piston rod allows gradual backing off of the spring load so the rest of the cylinder can be dismantled without danger or the need for any special tools.

VALVE CLOSURE TEST TAPES

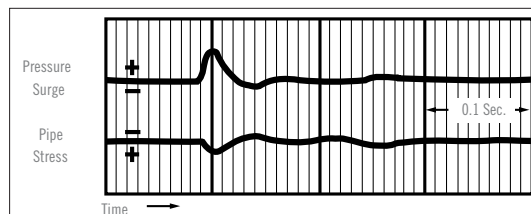

With Added Weight On Outer Edge of Disc

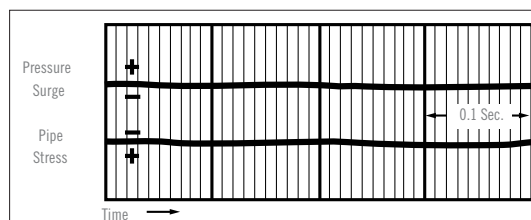

With Positive Closing Cylinder

DIMENSIONS

CLASS 1500

SIZE	END TO END	CV
4	13	357
6	15	826
8	18	1603
10	23	2585
12	25	3926
14	25	3926
16	29	5927

CLASS 2500

SIZE	END TO END	CV
4	13	357
6	18.5	826
8	23.5	1603
10	23.5	1603
12	28	2585
14	35	3926
16	35	3926
18	41	5927

NOTE: All dimensions in inches

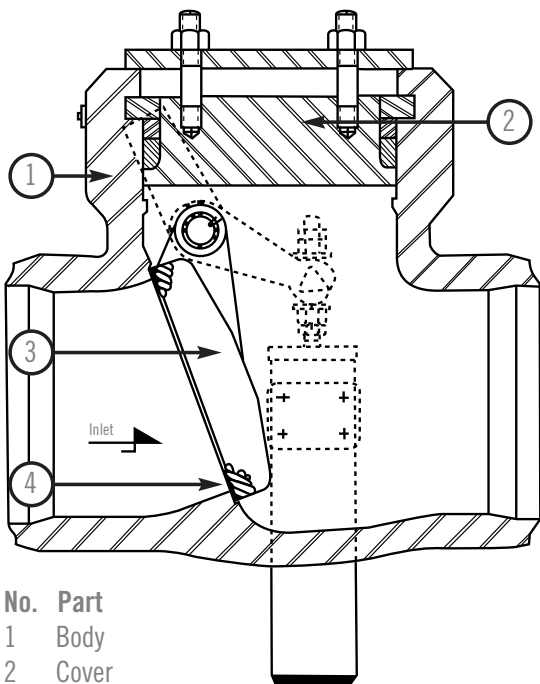

- No. Part
- 1 Body
- 2 Cover
- 3 Disc
- 4 Seats

The A&M valve does not use internal springs which are difficult to replace. Our design provides a closing spring external to the valve which is readily accessible and can be removed from the cylinder assembly with ease. Possible spring failure could not seize the shaft or prevent self-closing of the valve.

SPECIFICATIONS

- Size:** 3" through 24" standard.
- Pressure Ratings:** ASME Class 1500, 2500 (Special and higher ratings as applicable).
- Materials:** Cast steel with stainless steel or Cobalt Alloy Hard Facing trim. Other materials furnished on request.
- Cover Design:** Graphite Pressure Seal.
- Closing Device:** Spring loaded cylinder (air onrolled).
- Body Type:** Swinging disc design with inclined seat. Suitable for full ASME test pressures.
- Disc Assembly:** One-piece construction, pressure balanced against lateral thrust. Positive stop on disc. Disc suitable for full pump shut-off pressure.
- Shaft Bearing Design:** Single stuffing box for lower pressures. Double stuffing box for higher pressures. Shaft bushings are nitrided stainless steel.
- Seats:** Overlay stainless steel facings on both disc and body. Cobalt Alloy Hard Facings also available.
- Stuffing Box Packing:** Graphoil type.

The Atwood & Morrill® Swing Check Valve is designed to effectively prevent reverse flow and is ideally suited for high pressure feedwater and steam applications. Check valves provide tight shutoff, low maintenance and assured performance.

APPLICATION

Condensate pump discharge
Heater drains
Pump discharge
Main steam
High pressure feedwater & steam

DESCRIPTION

A unique one piece disc and disc arm that cannot spin or flutter. The valve is flow engineered to hold the disc in the full open position during a wider range of flows, and the swinging disc design prevents wedging or jamming.

Wide, flat, permanently aligned seats that minimize leakage.

Stainless steel seat facings and hard surfacing alloy available.

SPECIFICATIONS

Size:	4" – 24".
Pressure Ratings:	ANSI Class 900 – 2500.
Materials:	Cast steel with stainless steel or Cobalt Alloy Hard Facing trim. Other materials furnished on request.
Cover Design:	Graphite Pressure Seal.
Body Type:	Swinging disc design with inclined seat. Suitable for full ASME test pressures.
Disc Assembly:	One-piece construction, pressure balanced against lateral thrust. Positive stop on disc. Disc suitable for full pump shut-off pressure.
Seats:	Overlay stainless steel facings on both disc and body. Cobalt Alloy Hard Facings also available.

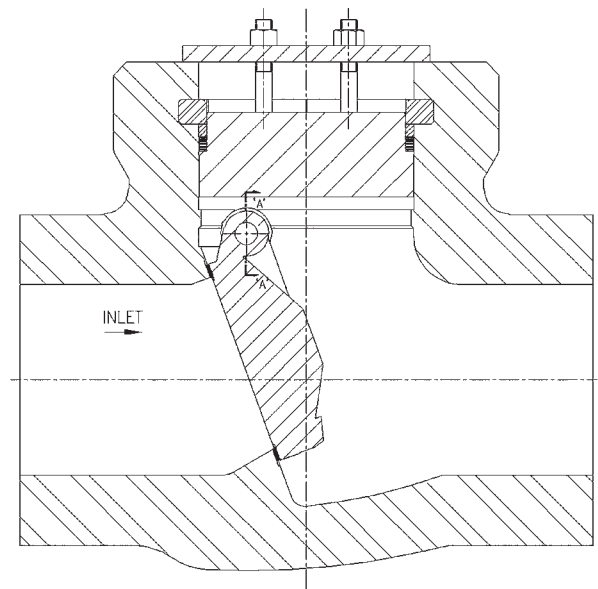
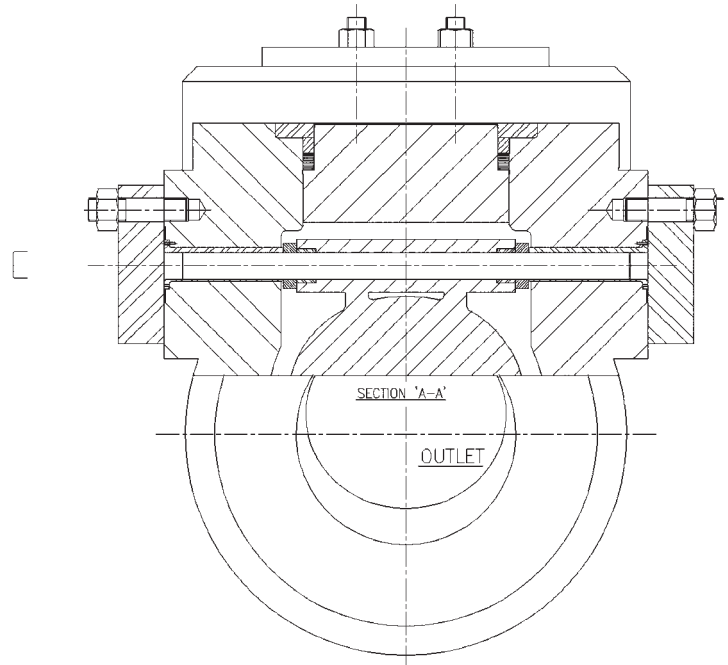

SWING CHECK VALVE

CLASS 1500

NOMINAL SIZE (IN.)	L	D	C	VH	BC	SR	DR	WEIGHT (LBS.)	CV
4	13.00	7.50	3.00	9.50	5.63	11.50	17.00	150	370
6	15.00	9.50	4.25	11.38	8.25	15.13	20.38	300	835
8	18.00	12.62	5.88	13.25	8.75	16.50	23.00	600	1,508
10	23.00	15.00	7.13	16.50	11.25	22.75	24.50	1,000	2,378
12	25.00	17.75	8.50	18.63	11.75	26.50	30.00	1,600	3,466
14	25.00	17.75	8.50	18.63	11.75	26.50	30.00	1,600	3,783
16	29.00	21.00	10.25	23.00	13.00	31.63	35.00	2,450	5,372

CLASS 2500

NOMINAL SIZE (IN.)	L	D	C	VH	BC	SR	DR	WEIGHT (LBS.)	CV
6	19.50	11.63	5.13	12.63	9.50	21.50	21.13	800	674
8	23.50	15.50	7.69	17.38	12.50	24.50	25.50	1,350	1,207
10	23.50	15.50	7.69	17.38	12.50	24.50	25.50	1,350	1,557
12	28.00	17.75	8.25	18.63	15.00	32.38	30.00	2,800	2,344
14	35.00	21.38	9.25	21.38	15.13	33.00	33.00	3,400	3,155
16	35.00	21.38	9.25	21.38	15.13	33.00	33.00	3,400	3,630
18	41.00	25.00	11.75	24.25	18.00	39.50	40.38	4,800	5,048
20	44.00	29.63	14.63	27.63	21.00	46.00	44.50	7,500	5,590
24	39.00	29.63	14.63	27.64	21.00	40.00	43.50	7,500	5,590

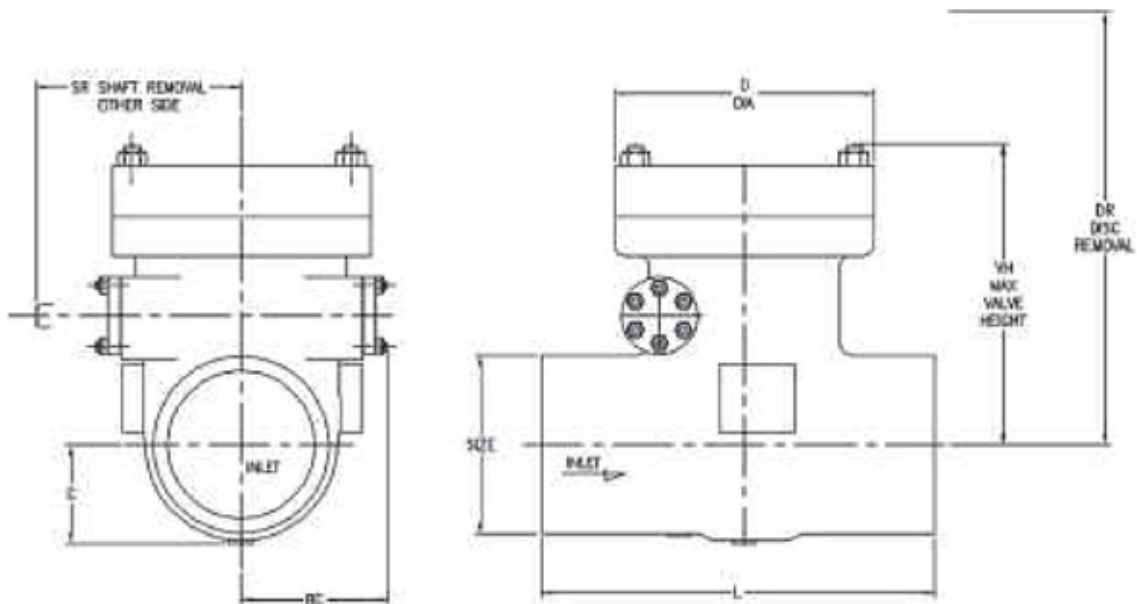

WYE GLOBE VALVE

The Atwood & Morrill® “Wye” Globe Valve is a highly engineered valve for utilities, power generation, industrial and process applications. Design variations assure optimum performance under a wide range of operating conditions and environments.

CONFIGURATIONS

Lift Check, Stop-Check, Stop

APPLICATIONS

Power

- Boiler Feedwater Pump non-return and stop
- Economizer inlet and stop
- Boiler outlet stop & non-return (multiple boilers)
- Feedwater Heater Isolation
- Main Steam Stop
- Auxiliary Equipment

Process & Refining

- Hydrogen service
- Hydro Cracker
- Hydrotreater
- Steam Service
- Pump Discharge



FEATURES

Designed for High Pressure, High Temperature operation to ASME B16.34.

TIGHT SHUTOFF

Hard-faced (CoCr), poppet fitting into the hard-faced seat in the body provides tight shutoff. The sturdy design is more resistant to pipeline stresses so the seat will remain tighter than wedge-type gate valve seat construction.

LOW PRESSURE DROP

Streamlined flow passages and lack of internal obstructions behind the poppet keep pressure drop low. Pressure drop may be as much as 70% less than conventional Globe and “Tee” pattern Globe Valves.

FAST OPERATION

A Wye Globe Valve can be closed considerably faster than a Gate Valve since the stroke is shorter. In the event of a tube failure in a feedwater heater, fast operation is important.

Removal of the valve cover, alone, allows full access to the internals. The interior of the valve body is easily inspected. Minor seat repairs may be made with ordinary lapping equipment. Major seat refurbishing can also be performed with portable grinding tools (available from the Service Department).

“DIRECT” SEATING OFFERS RESISTANCE TO THERMAL DISTORTION

Relatively few internal pieces in the valve design mean less problems of concentricity and movement with temperature change. When closed, valves cannot jam shut due to thermal contractions of the valve body.

SPACE REQUIREMENTS

The overall height of a Wye Globe Valve is less than a Gate Valve. This is an advantage when installing near catwalks, beneath the turbine floor and other restricted areas.

BYPASS PIPING

Bosses can be provided on the body permitting the use of integral by-pass piping.

Wye Type Globe Valves may have up to 70% lower pressure drop than conventional Globe Valves. Streamlined flow passages and a contoured entrance and exit reduce turbulence and pressure drop.

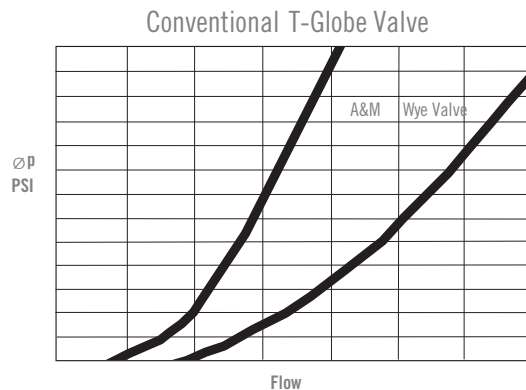

THERMAL COMPENSATION DEVICE

Our Thermal Compensation Device was patented in 2005. This innovative design relieves the thrust load built up in the valve stem, as the internal temperature rises and expansion of the materials occurs. Thermal growth of the valve stem can be up to 6-7 mm (1/4 inch). Without thermal compensation, stem growth can cause catastrophic failure of the valve stem, actuator or both.

DESIGN FEATURES

VALVE POSITION INDICATOR

Clearly indicates open and closed position of valve. Collar prevents stem rotation.

BOLTED YOKE CONSTRUCTION

With Cast or fabricated yoke rod construction for easy servicing.

SOFT SEAL

Tight reliable closure of the cover is assured by the use of our graphite seal ring.

Graphite seal ring allows quick access to internal parts.

Accommodates minor variations in mating parts where metal seals will not.

Lower cost for replacements.

BACKSEAT

Hardfaced inlay (CoCr) provides tight closure between stem shoulder and cover.

BODY

Streamlined shape for low pressure drop; carbon or alloy steel construction with Hardfaced guide ribs (CoCr) which provide continuous guiding of valve poppet in open or closed position. Guiding surfaces machined in same setup.

SEATS

Hard faced (CoCr) seats for tight shutoff and long service life, Stellite-to-Stellite contact increases seat tightness in valves exposed to high temperature.

OPERATORS

Include manual gear, electric, air and hydraulic types.

Thermal compensation kit available for high temperature applications.

COVER LOCKING AND RETAINING PLATE

Insure positive location and securing of cover against seal ring.

STANDARD STUFFING BOX DESIGN

Deep stuffing box with specially selected packings and nitrided guide bushings; stainless steel packing gland with separate alloy steel gland plate.

COVER

Forged steel construction provides symmetrical structure for even sealing on pressure seal and backseat faces.

STEM

High strength stainless steel, non-rotating construction.

CENTER RIB

With Hard faced overlay (CoCr) guides poppet.

POPPET

One-piece construction with Hard facing (CoCr) on guide surface and on seating surface.

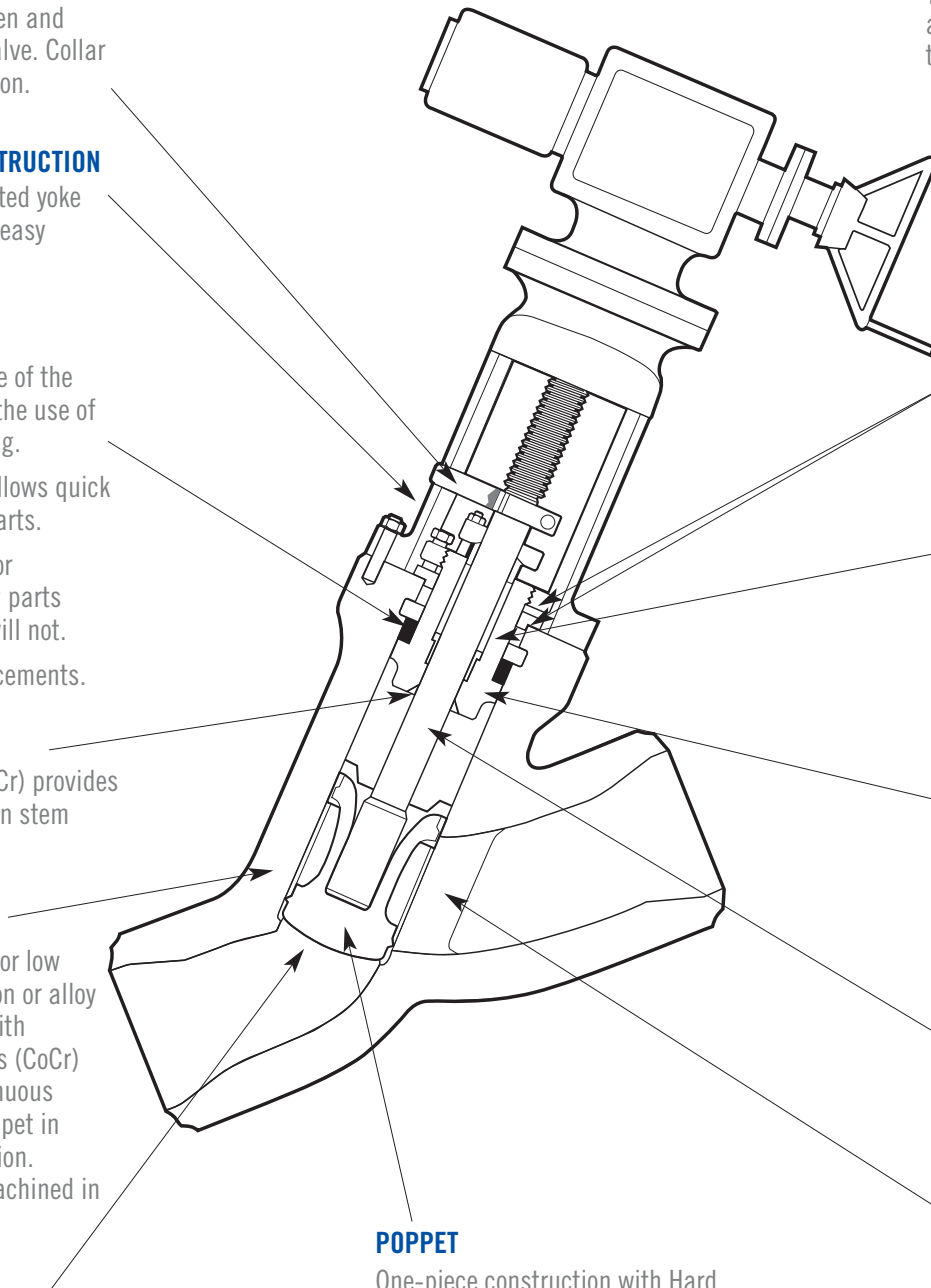

SPECIFICATIONS

- Design Standard:** ASME B16.34 and as required
- Pressure Class:** ASME Class 900-2500 and above
- Sizes: Materials:** Cast construction 6" - 24"
- Trim:** Carbon steel, alloy steel and stainless per ASTM specifications or applicable international standards
- Seats:** Stainless Steel
- Bonnet Design:** Hardfacing alloy #21 (CoCr)
Pressure seal with forged cover and graphite seal ring
- End connections:** Butt weld

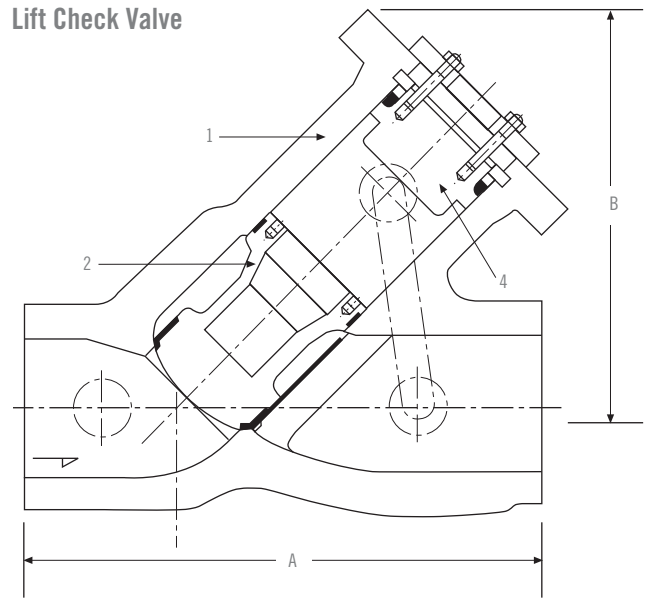

- 1. Body
- 3. Stem
- 2. Poppet
- 4. Cover

DIMENSIONS

CLASS 600 WYE STOP/STOP CHECK

SIZE (IN.)	A END TO END (IN.)	LIFT CHECK WEIGHT (LBS.)*	CV
18	43	4,000	7,825
20	47	4,100	7,250
24	55	8,800	13,875

CLASS 1500 LIFT CHECK, STOP CHECK AND STOP "WYE" GLOBE VALVES

SIZE (IN.)	A END TO END (IN.)	LIFT CHECK WEIGHT (LBS.)	*STOP/STOP CHECK WEIGHT (LBS.)	CV
6	27 3/4	505	1,000	950
8	30	958	1,400	1,610
10	36 1/4	1,785	2,600	2,550
12	43	2,910	4,600	3,525
14	43	2,840	4,700	3,535
16	54	4,090	8,400	6,220
18	63	5,000	8,400	6,220

CLASS 2500 LIFT CHECK, STOP CHECK AND STOP "WYE" GLOBE VALVES

SIZE (IN.)	A END TO END (IN.)	LIFT CHECK WEIGHT (LBS.)	*STOP/STOP CHECK WEIGHT (LBS.)	CV
6	24	505	1,100	630
8	30	1,158	1,500	1,125
10	36	2,050	4,000	1,790
12	43	3,570	6,000	2,620
14	49	5,400	7,700	3,790
16	49	5,480	8,600	3,790
18	58	8,000	13,600	5,000
20	58	8,180	13,600	5,000

*Manual Bevel Gear Actuator

Stop-Check & Stop Valve with Motor Operator

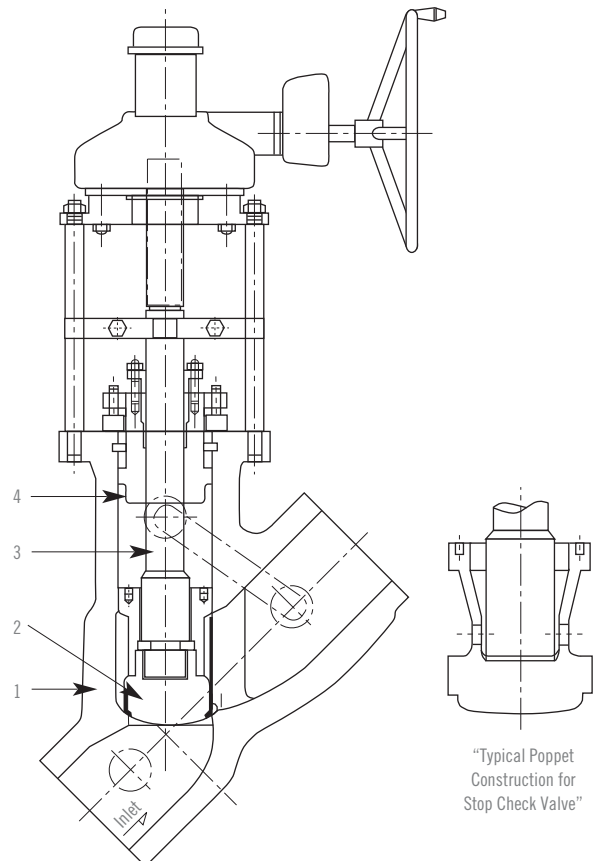

EQUALIZING PIPE - WYE GLOBE VALVE

Wye Stop/Check Valves are provided with an equalizing pipe connecting the area above the disc to the valve outlet. The equalizing pipe reduces any pressure build up over the disc allowing the higher pressure below to fully open the disc. This full disc lift reduces pressure drop.

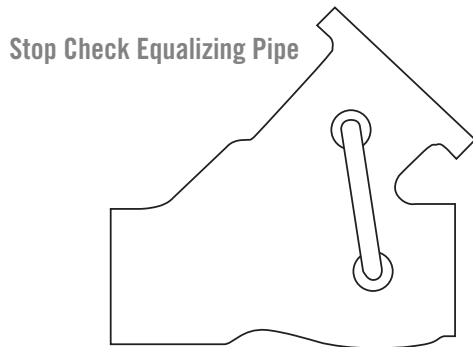

ELBOW DOWN VALVES

Elbow Down Valves are a special globe valve design used for downward vertical flow off a circulating pump. Elbow Down Valves are available for high pressure service in a range of sizes.



16" Class 1500 Elbow Down

3-WAY VALVES

The A&M 3-way bypass valve was introduced in 1925. We have continued to expand this product line by furnishing the largest 3-Way Valves required for power plants, worldwide.

FEATURES

In-line Body Design

The A&M 3-Way Valve features a "T" shape body. The inlet and bypass outlet are on the same center line. Therefore, piping layout is simplified and less expensive.

Uninterrupted Flow

When an A&M 3-Way Valve is used, accidental shutoff cannot occur. Full flow is maintained through one port or the other, or through both ports during operation of the valve. Transfer is automatic, so special sequencing required with dual or multi valve installations is not necessary.

Disc and Seat Design

The A&M design utilizes flat seats as experience proves it is easier to establish and maintain tightness. A flat seat can move in a horizontal plane and the valve will still remain tight. Alternate seating arrangements may not remain tight if subjected to lateral movement.

Guided Poppet

Stabilized seating in both directions ensures proper sealing. The guides also stay out of the normal flow path.

TYPICAL SERVICE

The A&M 3-Way Valve is designed for installations where uninterrupted flow control from one line to another is essential. The 3-Way Valve permits selection of two different flow patterns from the same valve.

DESIGN STANDARD

ASME B16.34

APPLICATIONS

High and Low Pressure
Feedwater Heater By-Pass

Dual Safety Valve Installations

Continuous Process Application

Bulk Storage Tank Switching

HRSR Economizer Diverting



FEEDWATER HEATER BY-PASS SERVICE

Valves in this service are designed to seat against full differential pressure of the feed pump. The motor or gear operators are sized, as standard construction, to move the disc from seat to seat against differential pressures of up to 200 to 400 psi for high pressure valves rated ASME Class 1500, and above, and against 100 psi differential for low pressure bypass valves rated to ASME Classes 150 and 300.

ADVANTAGES

- Eliminate two stop valves
- Eliminate one "Tee" fitting
- Eliminate side mounting of stop valves (which increases wear and maintenance)
- Make three field welds, not nine
- Simplify piping layout
- Eliminate one motor operator connection

COST SAVINGS

An A&M 3-Way Valve can provide significant savings in installation and maintenance costs.

SPECIFICATIONS

Size:	6 - 24 inch
Pressure Class:	150, 300, 1500 and 2500 ASME B16.34 Standard or Special Class, other ratings on request
Design Standard:	ASME B16.34 and as required
Base Materials:	Cast Carbon Steel, Alloys and Stainless Steel
Type of Operator:	Manual, Gear, Motor or Pneumatic
Trim Material:	Stainless Steel
Seating Surfaces:	Hardfacing Alloy #21 (CoCr)
Bonnet Design:	Bolted or Pressure Seal
End Connections:	Butt weld or Flanged

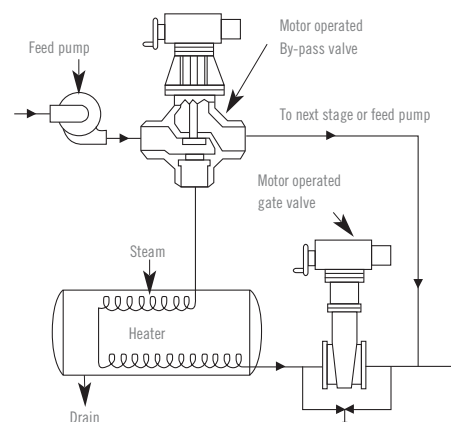

3-Way Valve Installation

VERSUS

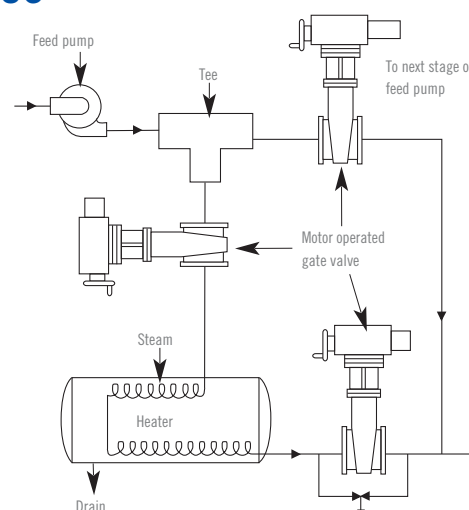

Gate Valve Installation

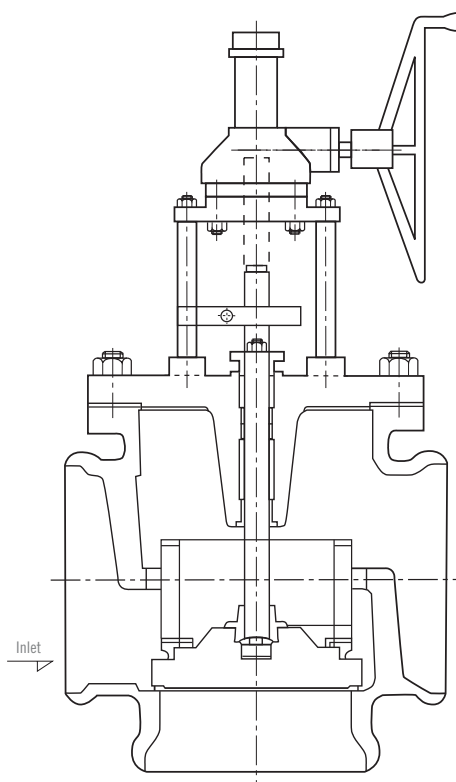

CLASS 300

VALVE SIZE	C. TO END	FACE TO FACE	OVERALL VALVE HEIGHT	APPROX. WT.	STRAIGHT THRU FLOW CV	ANGLE FLOW CV
	A	B	C	Lbs.		
6	8 3/8	16 3/4	34	600	289	450
8	10	20	46	700	547	903
10	12	24	50 7/8	1,000	867	1,431
12	12	24	48 1/8	1,400	1,675	2,819
14	13	26	52 1/2	2,000	2,037	3,424
16	13	26	54 5/8	2,200	2,045	3,361
18	18 1/2	37	59 7/8	2,500	2,817	4,657
20	20	40	69 1/2	3,600	4,017	6,700

CLASS 1500

VALVE SIZE	C. TO END	FACE TO FACE	OVERALL VALVE HEIGHT	APPROX. WT.	STRAIGHT THRU FLOW CV	ANGLE FLOW CV
	A	B	C	Lbs.		
6	10 1/2	21	41	1,500	268	446
8	12 1/2	25	45 3/4	1,600	470	783
10	15	30	51 1/2	2,000	745	1,240
12	17	34	61 3/8	3,000	1,058	1,762
14	19 1/2	39	65 3/4	7,400	1,597	2,627
16	19 1/2	39	65 3/4	7,400	1,608	2,665
18	24	48	78 1/4	8,100	2,337	3,908
20	24	48	78 1/4	8,100	2,348	3,852

CLASS 2500

VALVE SIZE	C. TO END	FACE TO FACE	OVERALL VALVE HEIGHT	APPROX. WT.	STRAIGHT THRU FLOW CV	ANGLE FLOW CV
	A	B	C	Lbs.		
6	12	24	42 7/8	1,600	266	435
8	15	30	52 3/4	3,900	454	727
10	16	32	60 1/4	7,000	719	1,136
12	19	38	66 1/8	7,400	1,009	1,588
14	19	38	66 1/8	7,400	1,055	1,763
16	22	44	70 7/8	8,500	1,553	2,500
18	22	44	70 7/8	8,500	1,604	2,683
20	27	54	82	10,500	2,292	3,773

NOTE: All dimensions in inches

Specific order requirements may cause dimensions to vary.

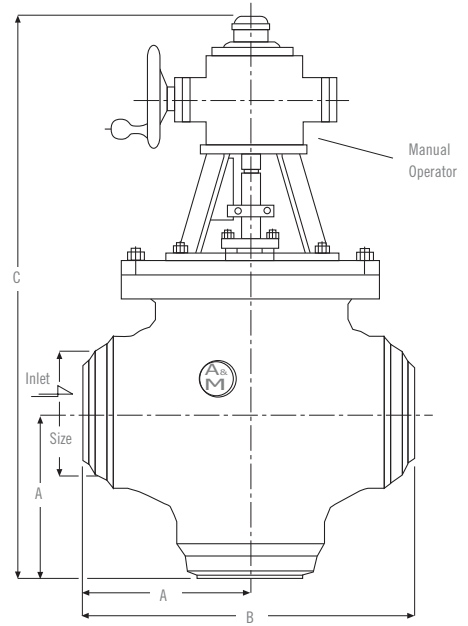

Low Pressure Design: Bolted Bonnet

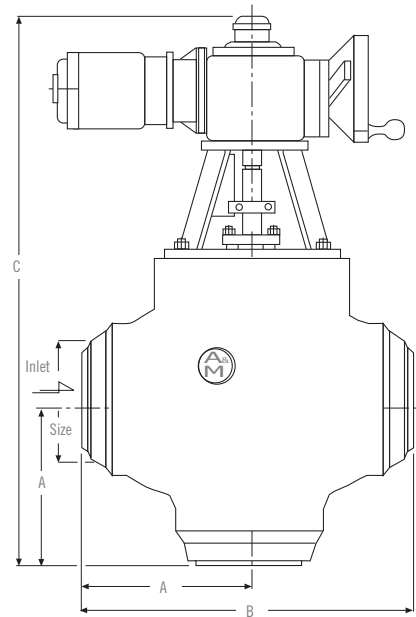

High Pressure Design: Pressure Sealed Bonnet

Atwood & Morrill® Parallel Slide Gate Valves are designed for high pressure, high temperature applications where tight shutoff and reliable operation are important.

Parallel Slide Gate valves are designed with independent discs and wide flat seats. More than just assuring fluid tightness, our design provides freedom from sticking and binding associated with wedge gate valves.

The wide flat seats in our gate valves assure a flat, intimate contact with the disc which creates a long difficult path for any incipient leakage.

The wide seating surfaces are designed to reduce seat bearing stress and guarantee long life. They also minimize the effect of minor damage to the surface as sealing occurs over the entire surface.

OTHER EXCEPTIONAL DESIGN FEATURES INCLUDE

Position seating and independent discs assure easy operation and perfect seating.

The higher the differential pressure, the tighter the shut off.

Hard faced seats (CoCr) reduce wear.

Self-cleaning action cleans seat every time valve is closed.

Slight rotation of the disc every time the valve closes equalizes wear.

External anti-rotation device and travel stop shows valve position and eliminates seat wear due to torquing forces associated with wedge gate valves.

APPLICATIONS

Feedwater heater isolation

Mainsteam stop and isolation

Temperature boiler blow-off

Recovery boiler emergency drain system

Boiler circulating pump isolation

Heater drains

Turbine drain systems

Sootblower steam

Safety valve isolation

Mud drum drain system

Blowdown

Pressure Relief Valve block valve

Cold reheat isolation



DESIGN FEATURES

YOKE ROD DESIGN

Provides easy access to packing gland and rigid support for operator.

PACKING GLAND

Two piece packing gland loads packing evenly, reducing possible damage to the stem.

DISCS

Slight wiping action of the disc removes foreign matter from the seat.

Rotating disc movement distributes wear evenly over the whole working surface.

Completely removed from the flow passage when open.

Self aligning, interchangeable discs assure tight shutoff and long life.

SEAT

Wide, flat seating surfaces are relatively immune to minor damage that can easily cause leakage in valves that utilize line contact seating.

Parallel seats can be lapped quickly (if required).

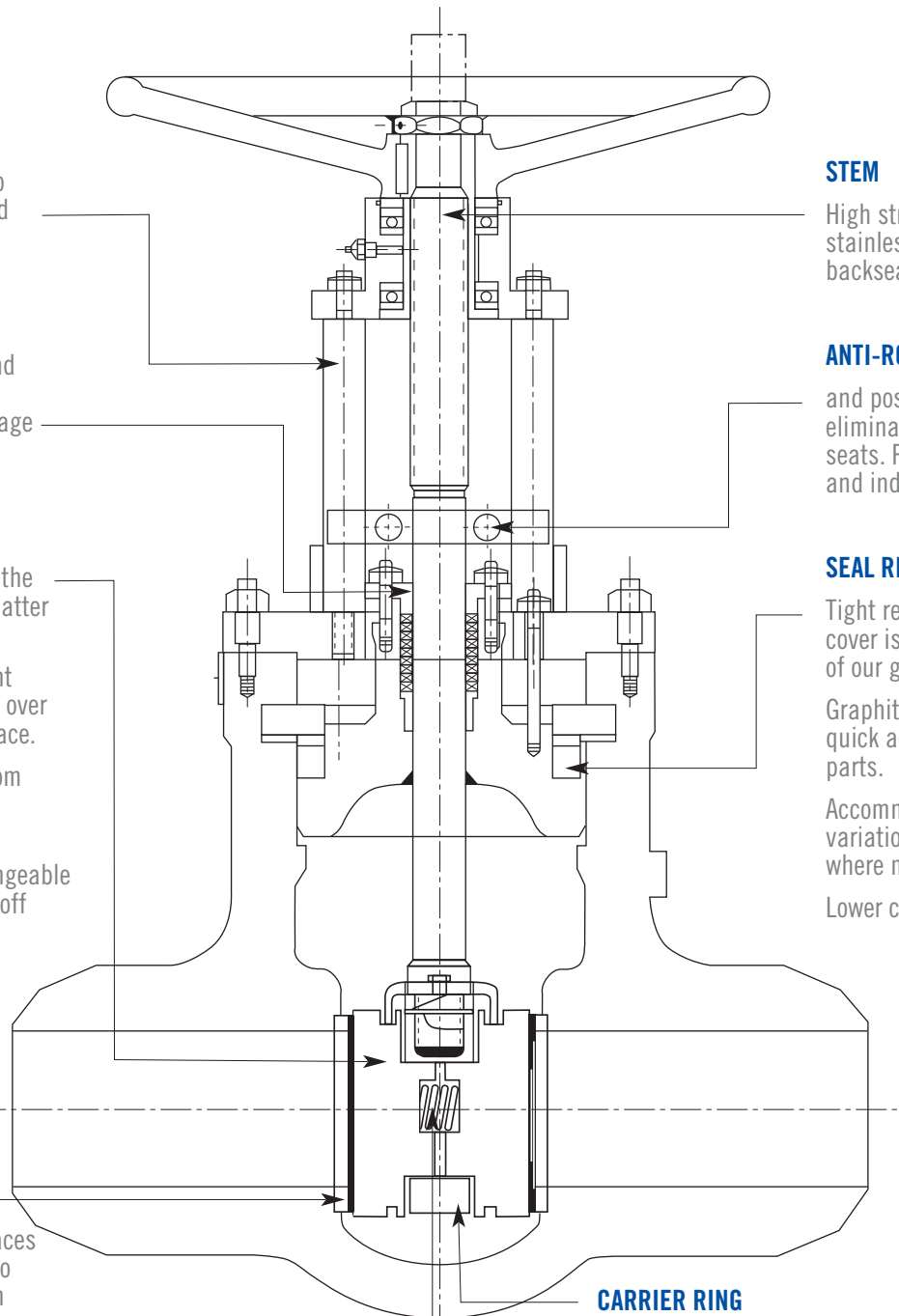

STEM

High strength heat treated stainless steel stem with backseat.

ANTI-ROTATION DEVICE

and position indicator eliminate torque wear of seats. Prevents stem turning and indicates valve position.

SEAL RING

Tight reliable closure of the cover is assured by the use of our graphite seal ring.

Graphite seal ring allows quick access to internal parts.

Accommodates minor variations in mating parts where metal seals will not.

Lower cost for replacements.

CARRIER RING

Durable carrier ring is securely threaded and pinned to the stem.

DISC SPRING

A light, non-corrodible spring keeps the discs in close contact with the seats when the valve is not under pressure.

TABLE OF DIMENSIONS CLASS 600 FIGURE NUMBER 2826

SIZE	L	H	W	CV	WEIGHT LBS.
16"	39	99.125	54.25	15920	3614
18"	43	107.375	60	20005	4614
20"	52	118.125	65.50	24536	6018
24"	61	137.875	78.75	36005	9260

CLASS 900 FIGURE NUMBER 2827

SIZE	L	H	W	CV	WEIGHT LBS.
6"	20	38	24	2300	360
8"	26	45	24	3950	675
10"	31	52	36	6200	1000
12"	36	58	36	8700	1400
14"	39	64	36	10550	1850
16"	43	69	*	13800	2500
18"	48	76	*	17500	4000
20"	52	82	*	21550	4500
24"	61	97	*	31000	6800

CLASS 1500 FIGURE NUMBER 2828

SIZE	L	H	W	CV	WEIGHT LBS.
6"	22	40	24	1900	560
8"	28	48	36	3250	950
10"	34	55	36	5100	1620
12"	39	60	36	7150	2440
14"	42	69	48	8600	3800
16"	47	75	*	11300	4750
18"	53	83	*	14250	5650
20"	58	87	*	17900	7800
24"	60	100	*	25700	11000

CLASS 2500 FIGURE NUMBER 2829

SIZE	L	H	W	CV	WEIGHT LBS.
6"	24	38	30	1150	850
8"	30	49	36	1950	1620
10"	36	58	36	3150	2750
12"	41	63	48	4450	3540
14"	44	69	48	5400	4850
16"	49	74	*	7050	6730
18"	55	77	*	8950	9060
20"	55	84	*	10900	10600
24"	62	103	*	15750	14680

*Gear or power operation recommended.

** Stellite is a trademark of Deloro Stellite Company.

NOTE: All dimensions in inches

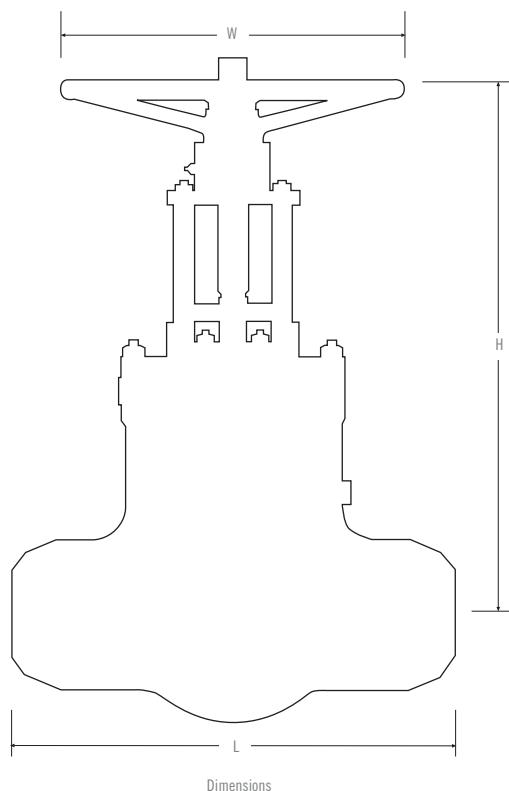

MATERIALS

DESCRIPTION	ALLOY STEEL
Body:	A217-C12A
Bonnet:	A182-F91
Stem:	Stainless Steel
Gasket:	Exfoliated Graphite
Disc/Seat:	Stellite Faced**
Gland Packing:	Exfoliated Graphite

MATERIALS

DESCRIPTION	CARBON STEEL	ALLOY STEEL	ALLOY STEEL
Body:	ASTM A216 Gr WCB	ASTM A217 Gr WC6	ASTM A217 Gr WC9
Bonnet:	ASTM A216 Gr WCB	ASTM A217 Gr WC6	ASTM A217 Gr WC9
Stem:	Stainless Steel		
Gasket:	Exfoliated graphite		
Seats:	ASTM A105 Stellite faced	ASTM A182 Gr F22 Stellite faced	
Gland Packing:	Exfoliated graphite ring		

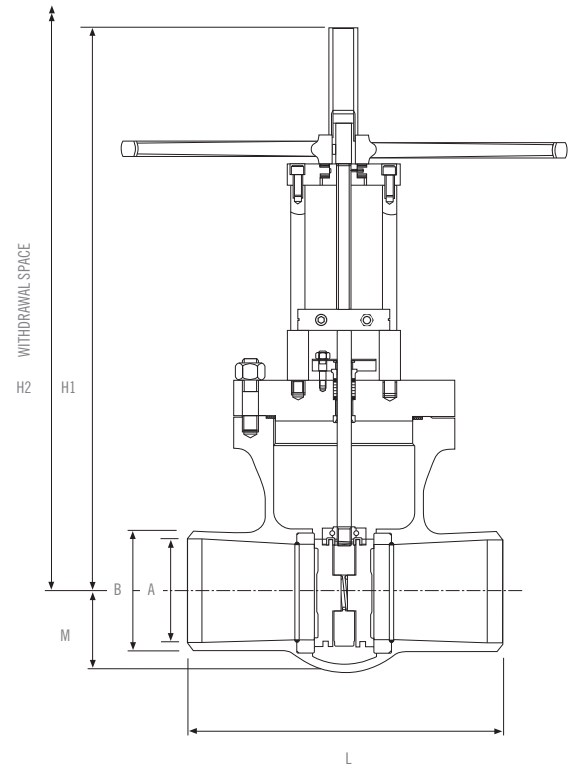

CLASS 600 FIGURE A21906W

NOMINAL SIZE (IN.)	A	B	L	M	H1	H2	WEIGHT (LBS.)	CV
5	4 3/4	13	15	4	29 1/8	34	203	*
6	5 3/4	14	18	4 1/2	33	38 1/4	256	2,461
8	7 5/8	16 1/2	23	4 3/4	40 5/8	48	478	4,197
10	9 1/2	20	28	6 7/8	48	57	767	6,656
12	11 3/8	22	32	8	55 1/2	66 3/8	1,146	9,918
14	12 1/4	23 3/4	35	8 5/8	-	71 7/8	1,462	11,880
16	14 1/4	27 1/8	39	9 3/4	-	82 1/8	2,030	15,920
18	16 1/8	29 1/4	43	10 3/4	-	90 5/8	2,906	20,005
20	18	32	47	11 7/8	-	99 1/4	3,629	24,536
22	19 3/4	32	51	13	-	107 1/4	4,526	*
24	21 1/2	37	55	14 1/8	-	117 7/8	5,860	36,005

* Consult factory

Withdrawal space shown refers to the valve being in the fully open position. Dimension H1 when not shown is dependent on size of operator fitted. Butt Weld Ends to ASME B16.25. Alternatives are available on request.

MATERIALS

DESCRIPTION	CARBON STEEL	ALLOY STEEL	ALLOY STEEL
Body:	ASTM A216 Gr WCB	ASTM A217 Gr WC6	ASTM A217 Gr WC9
Bonnet:	ASTM A216 Gr WCB	ASTM A217 Gr WC6	ASTM A217 Gr WC9
Stem:	Stainless Steel		
Gasket:	Exfoliated graphite		
Seats:	ASTM A105 Stellite faced	ASTM A182 Gr F22 Stellite faced	
Gland Packing:	Exfoliated graphite ring		

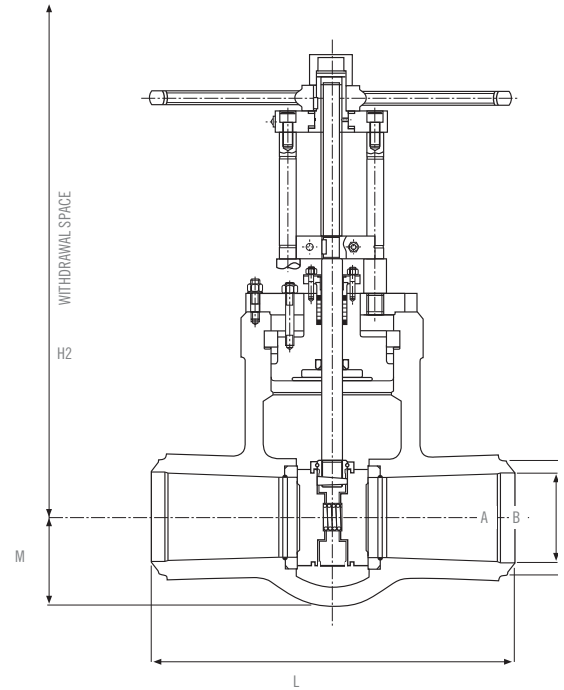

CLASS 1000 FIGURE A21910W

NOMINAL SIZE (IN.)	A	B	L	M	H1	H2	WEIGHT (LBS.)	CV
5	4.57	5.67	17	4 1/4	29 5/8	31 1/4	183	*
6	5.51	6.77	20	5 1/8	34 1/4	41 1/2	309	1,926
8	7.16	8.78	26	6 1/8	41 3/8	50 1/2	514	3,458
10	9.05	10.94	31	7 1/2	49 5/8	61 3/8	913	5,495
12	10.74	12.95	36	8 5/8	-	72	1,385	7,858
14	11.81	14.25	39	9 1/2	-	77 7/8	1,771	9,588
16	13.54	16.26	43	10 5/8	-	88	2,540	12,665
18	15.24	18.26	48	11 7/8	-	99 1/8	3,614	16,005
20	16.96	20.31	52	13	-	107 3/8	4,614	20,113
22	18.74	22.32	56	14 1/4	-	118 1/8	6,018	*
24	20.35	24.37	61	15 3/8	-	126 1/4	7,445	29,588

*Consult factory

Withdrawal space shown refers to the valve being in the fully open position. Dimension H1 when not shown is dependent on size of operator fitted. Butt Weld Ends to ASME B16.25. Alternatives are available on request.

MATERIALS

DESCRIPTION	CARBON STEEL	ALLOY STEEL	ALLOY STEEL
Body:	ASTM A216 Gr WCB	ASTM A217 Gr WC6	ASTM A217 Gr WC9
Bonnet:	ASTM A216 Gr WCB	ASTM A217 Gr WC6	ASTM A217 Gr WC9
Stem:	Stainless Steel		
Gasket:	Exfoliated graphite		
Seats:	ASTM A105 Stellite faced	ASTM A182 Gr F22 Stellite faced	
Gland Packing:	Exfoliated graphite ring		

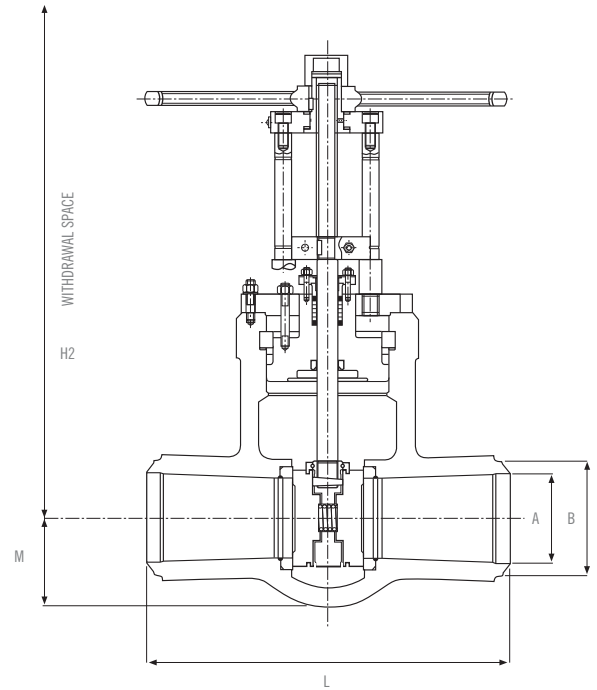

CLASS 1700 FIGURE A21917W

NOMINAL SIZE (IN.)	A	B	L	M	H1	H2	WEIGHT (LBS.)	CV
5	4.17	5.67	19	43/4	30	36 7/8	274	*
6	5.04	6.77	22	53/4	34 1/4	42 5/8	444	1,491
8	6.57	8.78	28	7	42 5/8	53 5/8	849	2,595
10	8.23	10.94	34	8 1/2	62	65 1/4	1,492	4,151
12	9.80	12.95	39	9 3/4	-	75 3/8	2,264	6,038
14	10.75	14.25	42	10 1/2	-	81 1/2	3,440	7,255
16	12.32	16.26	47	12	-	92 3/8	4,250	9,432
18	13.86	18.26	53	13 3/4	-	101 1/8	5,615	12,243
20	15.43	20.31	58	14 7/8	-	112 3/4	7,765	15,297
22	17.00	22.32	62	16 1/8	-	119 1/4	9,566	*
24	18.54	24.37	66	17 5/8	-	131 3/8	12,524	22,433

* Consult factory

Withdrawal space shown refers to the valve being in the fully open position. Dimension H1 when not shown is dependent on size of operator fitted. Butt Weld Ends to ASME B16.25. Alternatives are available on request.

MATERIALS

DESCRIPTION	CARBON STEEL	ALLOY STEEL	ALLOY STEEL
Body:	ASTM A216 Gr WCB	ASTM A217 Gr WC6	ASTM A217 Gr WC9
Bonnet:	ASTM A216 Gr WCB	ASTM A217 Gr WC6	ASTM A217 Gr WC9
Stem:	Stainless Steel		
Gasket:	Exfoliated graphite		
Seats:	ASTM A105 Stellite faced	ASTM A182 Gr F22 Stellite faced	
Gland Packing:	Exfoliated graphite ring		

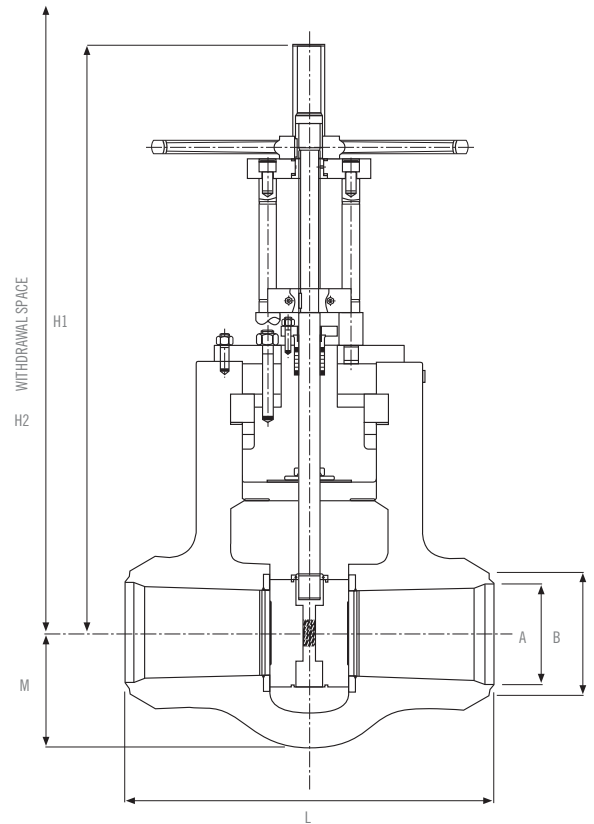

CLASS 2500 FIGURE A21925W

NOMINAL SIZE (IN.)	A	B	L	M	H1	H2	WEIGHT (LBS.)	CV
5	3.78	5.67	21	5 1/4	29 5/8	37	353	*
6	4.45	6.77	24	6	33 7/8	43 1/8	560	1,022
8	5.86	8.78	30	7 1/2	41 3/4	53 1/8	1,067	1,818
10	7.36	10.94	36	9 1/8	-	63 5/8	1,920	3,006
12	8.78	12.95	41	10 3/4	-	75 1/4	3,023	4,296
14	9.64	14.25	44	12	-	82 3/8	4,015	5,205
16	11.06	16.26	49	13 5/8	-	94 1/2	6,000	6,798
18	12.48	18.26	55	15	-	103 1/8	8,010	8,875
20	13.89	20.31	60	16 3/8	-	113 1/4	10,545	10,809
22	15.31	22.32	64	17 7/8	-	121 3/8	13,279	*
24	16.69	24.37	68	19 1/2	-	132 1/4	17,148	15,974

*Consult factory

Withdrawal space shown refers to the valve being in the fully open position. Dimension H1 when not shown is dependent on size of operator fitted. Butt Weld Ends to ASME B16.25. Alternatives are available on request.

MATERIALS

DESCRIPTION	
Body:	ASTM A105
Bonnet:	ASTM A105
Stem:	Stainless Steel
Gasket:	Exfoliated graphite spiral wound
Seats:	Grade 6 stellite
Disc:	13% Cr Stainless Steel hardened
Gland Packing:	Exfoliated graphite and braided carbon fiber

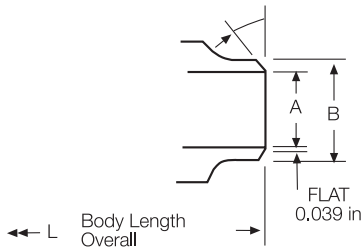
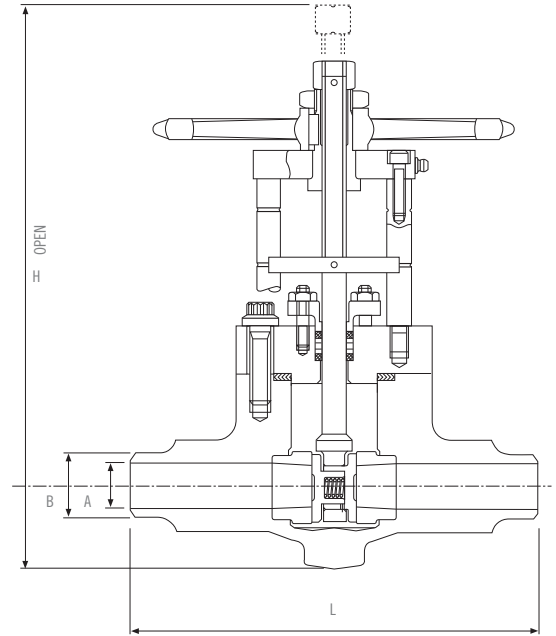

FIGURE A21906W

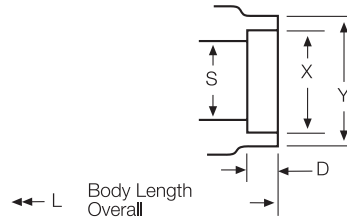

FIGURE A21906S

CLASS 600

NOMINAL SIZE	BUTT WELD				SOCKET WELD					
	L	A	B	WEIGHT	L	S	X	Y	D	WEIGHT
1/2	-	-	-	-	5 1/2	23/32	0.865/0.855	1 9/16	3/8	10
3/4	7 1/2	0.752/0.732	1 1/16	12	5 1/2	23/32	1.075/1.065	1 9/16	1/2	11
1	8 1/2	0.967/0.947	1 11/32	19	6 1/2	15/16	1.340/1.330	1 25/32	1/2	16
1 1/4	9	1.288/1.268	1 11/16	31	7	1 1/4	1.685/1.675	2 1/8	1/2	29
1 1/2	9 1/2	1.508/1.488	1 15/16	46	7 1/2	1 1/2	1.925/1.915	2 13/32	1/2	44
2	11 1/2	1.949/1.929	2 13/32	71	9 1/2	1 5/16	2.416/2.406	2 29/32	5/8	66

Butt Weld Ends to ASME B16.25. Alternatives are available on request.

MATERIALS

DESCRIPTION	
Body:	ASTM A105
Bonnet:	ASTM A105
Stem:	Stainless Steel
Gasket:	Exfoliated graphite spiral wound
Seats:	Grade 6 stellite
Disc:	13% Cr Stainless Steel hardened
Gland Packing:	Exfoliated graphite and braided carbon fiber
Bonnet bolts:	ASTM-A193 Grade B7

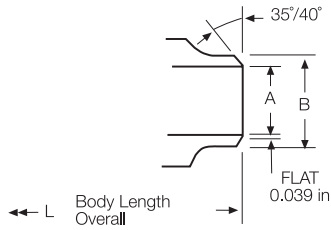
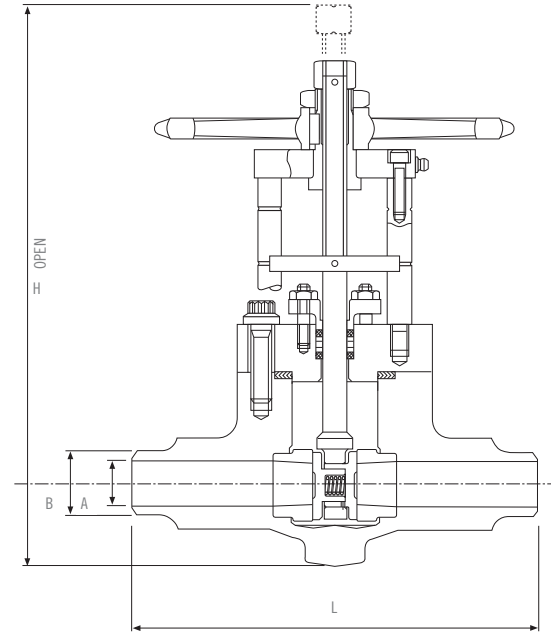

FIGURE A21909W

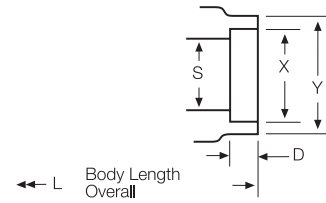

FIGURE A21909S

CLASS 900

NOMINAL SIZE	BUTT WELD				SOCKET WELD					
	L	A	B	WEIGHT	L	S	X	Y	D	WEIGHT
1/2	-	-	-	-	5 1/2	23/32	0.865/0.855	1 1/2	3/8	11
3/4	9	0.622/0.602	1 1/16	13	5 1/2	23/32	1.075/1.065	1 9/16	1/2	12
1	10	0.825/0.805	1 11/32	19	8	25/32	1.340/1.330	1 15/32	1/2	19
1 1/4	11	1.170/1.150	1 11/16	35	9	1 1/8	1.685/1.675	2 1/4	1/2	33
1 1/2	12	1.347/1.327	1 15/16	50	10	1 9/32	1.925/1.915	2 9/16	1/2	48
2	14 1/2	1.697/1.677	2 13/32	73	12	1 21/32	2.416/2.406	3 3/16	5/8	71

Butt Weld Ends to ASME B16.25. Alternatives are available on request.

BONNETLESS TYPE 1/2" & 3/4" SIZES

MATERIALS - CARBON STEEL VALVES

Body:	Carbon Steel - Forged	ASTM-A105
Gland Ring:	Nickel molybdenum alloy	
Stem:	Stainless Steel	
Seats:	Grade 6 Stellite	
Discs:	Nickel molybdenum alloy	
Gland Packing:	Exfoliated graphite & braided carbon fiber	

MATERIALS - ALLOY STEEL VALVES

Body:	Carbon Steel - Forged	ASTM-A182-F22
Gland Ring:	Nickel molybdenum alloy	
Stem:	Stainless Steel	
Seats:	Grade 6 Stellite	
Discs:	Nickel molybdenum alloy	
Gland Packing:	Exfoliated graphite & braided carbon fiber	

PRESSURE SEAL BONNET TYPE 1" TO 2" SIZES

MATERIALS - CARBON STEEL VALVES

Body:	Carbon Steel - Forged	ASTM-A105
Bonnet:	Alloy Steel - Forged	ASTM A182-F22
Back Seat:	Nickel molybdenum alloy	
Locking Ring:	13% Cr Stainless Steel	
Holding Ring:	13% Cr Stainless Steel	
Gasket:	Exfoliated graphite	
Stem:	Stainless Steel	
Seats:	Grade 6 Stellite	
Discs:	Nickel molybdenum alloy	
Gland Packing:	Exfoliated graphite & braided carbon fiber	

MATERIALS - ALLOY STEEL VALVES

Body:	Alloy Steel - Forged	ASTM-A182-F22
Bonnet:	Alloy Steel - Forged	ASTM A182-F22
Back Seat:	Nickel molybdenum alloy	
Locking Ring:	High strength aust. s.s.	ASTM A638-660
Holding Ring:	13% Cr Stainless Steel	
Gasket:	Exfoliated graphite	
Stem:	Stainless Steel	
Seats:	Grade 6 Stellite	
Discs:	Nickel molybdenum alloy	
Gland Packing:	Exfoliated graphite & braided carbon fiber	

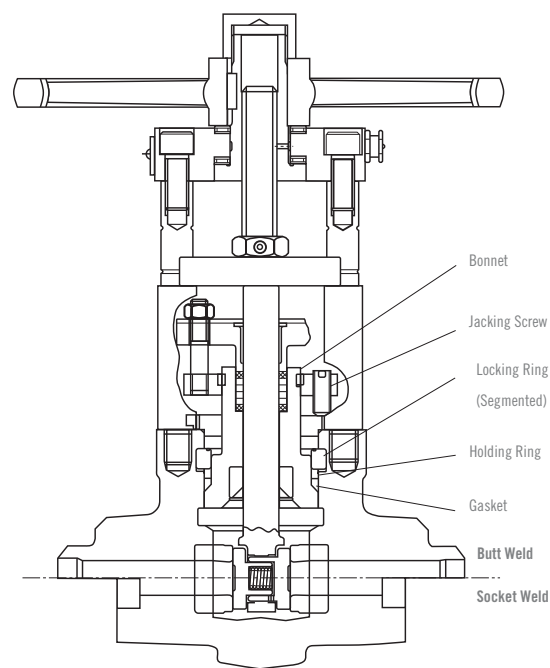
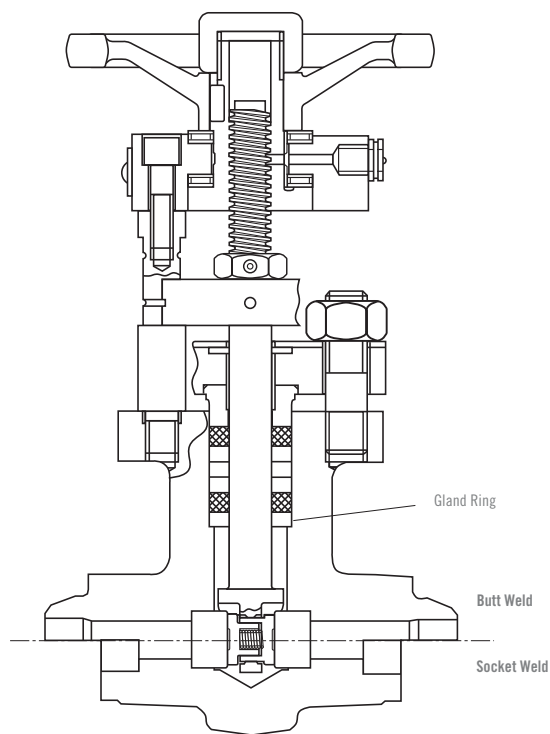

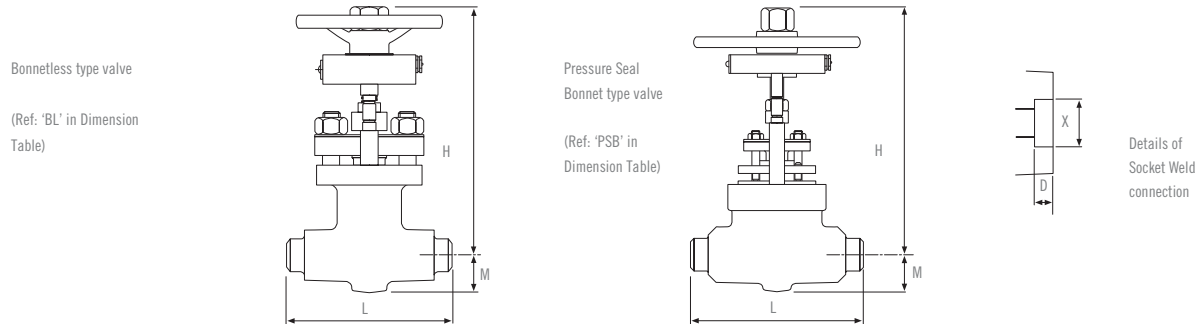

	NOMINAL SIZE	H	M	BUTT WELD					SOCKET WELD				
				TYPE	L	A	B	WEIGHT	TYPE	L	X	D	WEIGHT
Class 1500 Butt Welds Valves Figure No. A21915S	1/2	8 1/4	1 1/4	BL	5 1/2	0.50	0.94	13lb	BL	4	0.857	1/2	12lb
	3/4	10 3/8	1 9/16	PSB	7 9/16	0.61	1.10	23	PSB	5	1.070	1/2	22
	1	10 3/8	1 9/16	PSB	7 9/16	0.81	1.38	23	PSB	5	1.335	1/2	22
	1 1/4	12 5/8	2	PSB	9 1/8	1.16	1.69	46	PSB	6 1/2	1.680	1/2	43
	1 1/2	15 3/4	2 5/8	PSB	11	1.34	2.05	91	PSB	7 7/8	1.920	1/2	87
	2	15 3/4	2 5/8	PSB	11	1.69	2.44	91	PSB	7 7/8	2.411	5/8	87
Class 2500 Butt Welds Valves Figure No. A21925S	1/2	8 1/2	1 1/4	BL	5 1/2	0.50	0.94	13lb	BL	4	0.857	1/2	12lb
	1/2*	8 1/4 (10 3/8)	1 1/4 (1 9/16)	BL	5 1/2	0.50	1.10	13	PSB	5	1.070	1/2	22
	1	10 3/8	1 9/16	PSB	7 9/16	0.60	1.38	23	PSB	5	1.335	1/2	22
	1 1/4	12 5/8	2	PSB	9 1/8	0.89	1.81	46	PSB	6 1/2	1.680	1/2	43
	1 1/2	15 3/4	2 5/8	PSB	11	1.10	2.17	91	PSB	7 7/8	1.920	1/2	87
	2	15 3/4	2 5/8	PSB	11	1.50	2.56	91	PSB	7 7/8	2.411	5/8	87
Class 3100 Butt Welds Valves Figure No. A21931S	1/2	8 1/4	1 1/4	BL	5 1/2	0.50	0.94	13lb	BL	4	0.857	1/2	12lb
	3/4*	8 1/4 (10 3/8)	1 1/4 (1 9/16)	BL	5 1/2	0.50	1.10	13	PSB	5	1.070	1/2	22
	1	10 3/4	1 1/2	PSB	7 9/16	0.60	1.38	23	PSB	5	1.335	1/2	22
	1 1/4	12 5/8	2	PSB	9 1/8	0.89	1.81	46	PSB	6 1/2	1.68	1/2	43
	1 1/2	15 3/4	2 5/8	PSB	11	1.10	2.17	91	PSB	7 7/8	1.920	1/2	87
	2	15 3/4	2	PSB	11	1.50	2.56	91	PSB	7 7/8	2.411	5/8	87

*Figures in parentheses relate to Socket Weld End valves.

MATERIALS

DESCRIPTION	
Body:	ASTM A216-WCB
Bonnet:	ASTM A105
Stem:	Stainless Steel
Gasket:	Exfoliated graphite spiral wound
Seats:	Grade 6 stellite
Disc:	13% Cr Stainless Steel hardened
Gland Packing:	Exfoliated graphite and braided carbon fiber
Bonnet bolts:	ASTM-A193 Grade B7

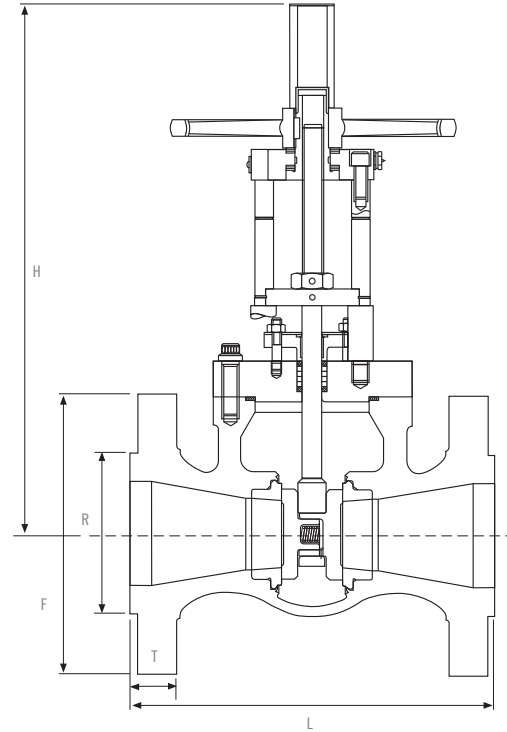

CLASS 600 FIGURE A21906

FLANGED

NOMINAL SIZE IN	T IN	F IN	H IN	L IN	R IN	WEIGHT LB
2 1/2	1 3/8	7 1/2	16 1/4	13	4 1/8	90
3	1 1/2	8 1/4	16 1/4	14	5	114
4	1 3/4	10 3/4	20	14	6 3/16	183

Flanged to ASME B16.5. Alternatives are available on request.

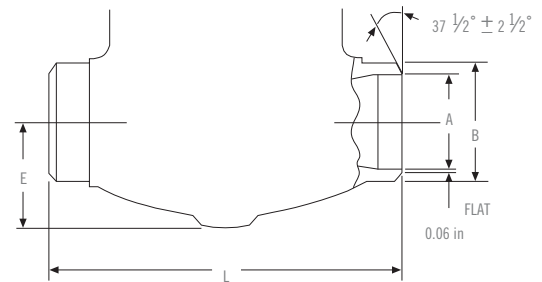

Other dimensions as flanged valves

CLASS 600 FIGURE NO. A21906W

BUTT WELD

NOMINAL SIZE IN	E IN	L IN	A IN	B IN	WEIGHT LB
2 1/2	2 9/16	8 1/2	2.32	2.88	66
32	5/8	10	2.87	3.50	68
43	1/8	12	3.81	4.50	97

Flanged to ASME B16.5. Alternatives are available on request.

MATERIALS - CARBON STEEL VALVES

Body:	Carbon Steel - Forged	ASTM-A105
Bonnet:	Sizes 2 1/2 & 3in: Alloy steel - forged ASTM A182-F22 Size 4" (100mm): Carbon Steel - forged ASTM-A105	
Back Seat:	Nickel molybdenum alloy	
Locking Ring:	13% Cr Stainless Steel	
Holding Ring:	13% Cr Stainless Steel	
Gasket:	Exfoliated graphite	
Stem:	Stainless Steel	
Belt Eye:	Sizes 2 1/2 & 3in: Austenitic SS ASTM A453 Grade 660B Size 4in: Alloy Steel -forged ASTM-182-F22	
Seats:	Grade 6 Stellite	
Discs:	Nickel molybdenum alloy	
Gland Packing:	Exfoliated graphite & braided carbon fiber	

MATERIALS - ALLOY STEEL VALVES

Body:	Alloy Steel - Forged	ASTM-A182-F22
Bonnet:	Alloy steel - forged	ASTM A182-F22
Back Seat:	Nickel molybdenum alloy	
Locking Ring:	Class 900, 1500, 2500 valves: 13% Cr Stainless Steel Class 3100, 3600 valves: ASTM A638 Grade 660	
Holding Ring:	13% Cr Stainless Steel	
Gasket:	Exfoliated graphite	
Stem:	Stainless Steel	
Belt Eye:	Sizes 2 1/2 & 3in: Austenitic SS ASTM A453 Grade 660B Size 4in: Alloy Steel - forged ASTM-182-F22	
Seats:	Grade 6 Stellite	
Discs:	Nickel molybdenum alloy	
Gland Packing:	Exfoliated graphite & braided carbon fiber	

BUTT WELD END VALVES

Class 900	Figure No. A21909W
Class 1500	Figure No. A21915W
Class 2500	Figure No. A21925W
Class 3100	Figure No. A21931W
Class 3600	Figure No. A21936W
Nominal Sizes:	inch 2 1/2 3 4

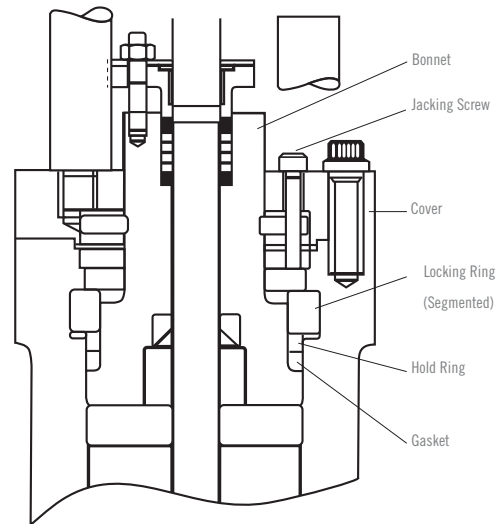
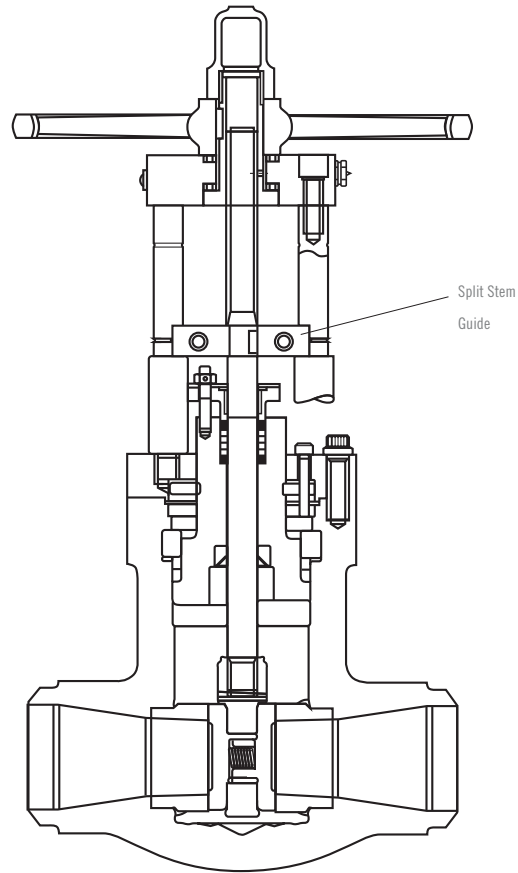

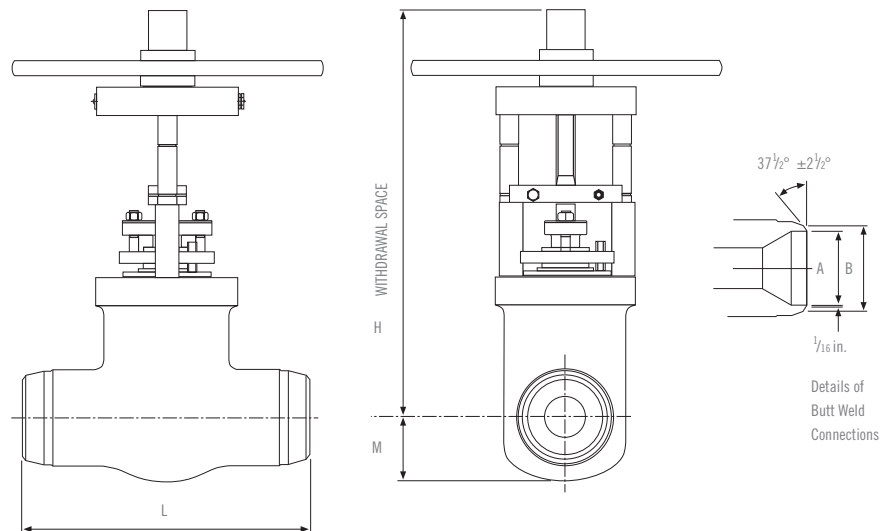

FIGURE NO. A21909W

CLASS 900

NOMINAL SIZE IN	A IN	B IN	H IN	L IN	M IN	WEIGHT LB
2 1/2	2.12	3.34	17	10	2 5/8	77
3	2.62	3.93	17 1/8	12	2 5/8	81
4	3.43	4.72	24 1/4	14	3 3/4	180

FIGURE NO. A21915W

CLASS 1500

NOMINAL SIZE IN	A IN	B IN	H IN	L IN	M IN	WEIGHT LB
2 1/2	2.12	3.34	17	10	2 5/8	77
3	2.62	3.93	17 1/8	12	2 5/8	81
4	3.43	4.92	24 1/4	16	3 3/4	189

FIGURE NO. A21925W CLASS 2500

FIGURE NO. A21931W CLASS 3100 Size 2 1/2" only, Alloy Steel only

FIGURE NO. A21936W CLASS 3600 Sizes 3 & 4" only, Alloy Steel only

CLASS 2500, 3100 & 3600

NOMINAL SIZE IN	A IN	B IN	H IN	L IN	M IN	WEIGHT LB
2 1/2	1.77	3.34	17	13	2 3/4	90*
3	2.17	3.93	17 1/8	14 1/2	2 3/4	95*
4	2.62	4.92*	24 1/4	18	3 3/4	205*

*Weights shown in column are for Fig. A21925W. Other valves: Fig A21931W 2 1/2 in – 106 lb, Fig. A21936W 3in – 110 lb., 4 in – 253 lb., 4 in B Dimension – 5.1”.

Butt Weld Ends to ASME B16.25 Alternatives are available on request.

An equalizing device allows the relief of fluid which might otherwise become trapped in the intergate space (center cavity) of the valve body. It also provides an escape for fluid displaced by the stem assembly when closing the valve.

INTERGATE RELIEF

ASME standards, ASME B16.34, Valves - Flanged, Threaded and Welded End, paragraph 2.3.3, and ASME B31.1, Power Piping Code, paragraph 107.1, require users of double seated valves to provide a means in design, installation, or operation to prevent over pressurization due to thermal expansion of trapped fluids within the valve body. This fluid expansion can cause pressures that exceed the valve materials' strength causing excessive leakage or possibly even rupture. An equalizing system can be provided on all 6" and larger Parallel Slide Gate Valves to meet ASME B16.34 requirements.

EXTERNAL INTERGATE LINE WITH ISOLATION VALVE

The equalizing pipe connects the valve's center cavity to the inlet end of the valve allowing displaced fluid to transfer up-stream. The intergate relief isolation valve is kept open during normal operating conditions. Closing the intergate valve isolates flow in the upstream direction when required for hydrostatic testing or other reason. Note: in certain instances such as Feedwater Heater Isolation the intergate is installed to the "down-stream" side of the outlet valve for isolation.

EXTERNAL INTERGATE PIPE ONLY

We also can provide an external equalizing pipe only, without valve. Bypass valves can be supplied along with associated piping as an integral unit to the main valve if required. The bypass valve is used to equalize pressure on either side of a closed main valve. It can also be used to warm up downstream pipe work with the main valve closed.

INTERNAL DRILLED DISC

Drilling a hole through the center of the upstream valve disc can be a cost-effective design protection method, but it causes the valve to be permanently unidirectional. This method is also recommended for smaller valves where an external piping arrangement may not fit or be suitable.

External Intergate Pipe and By-pass Diagram

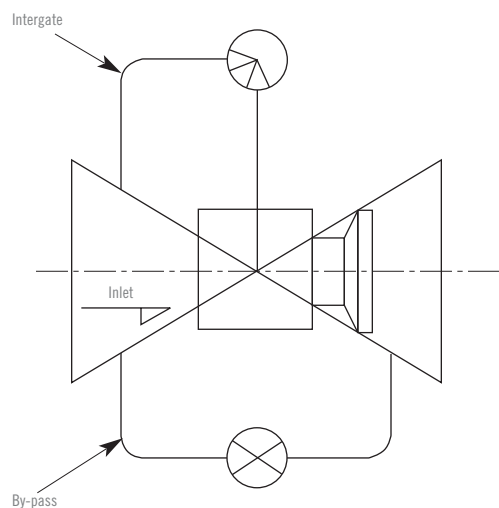

OTHER METHODS

Customer Requirements

To meet customer requirements, a bonnet vent, drain or relief valve can also be used for over pressurization protection. These methods require additional customer piping to remove fluid from the bonnet cavity.

Operation - Procedure

If a double seated valve does not have a design feature for over pressurization protection, the user can revise operating procedures to include opening and closing the valve disc to relieve built up bonnet cavity pressure. This must be done after any heating or cooling of the line, during a start up or shut down, and any other time fluid thermal expansion is suspected.

CONCLUSION

To meet ASME requirements and prevent damage, some type of over pressurization protection, by method or design, is required.

Determining the most suitable protection for your system is the responsibility of the valve user and should be decided at time of specification prior to purchase. For additional help call our Service or Sales Departments.

24" Parallel Slide Gate Valve with Stem Extension



VEE PORT DESIGN FOR FLOW REGULATION

A “Vee” port design is an optional feature for gate valves. The “Vee” port is integrally cast into the outlet seat ring. Flow regulation is accomplished by progressive opening of the disc which uncovers the “Vee” notch.

The “Vee” Port Seat was originally developed for tight shut off drain applications where control or throttling was required for short durations. This severe service is very tough on standard gate valves which are designed to be used in the full open or closed position. The “Vee” Port Parallel Slide Gate meets these demanding requirements.

OPERATION

Progressive opening of the valve disc uncovers more of the “Vee” notch for flow regulation. Unlike globe valves the “Vee” is slightly recessed protecting the actual seating surface from wear.

CONSTRUCTION

“Vee” Ported Seats can be supplied in any A&M Parallel Slide Gate valve. Located on the outlet side of the valve and paired with a standard inlet seat, the “Vee” is integrally cast into the outlet seat ring and possesses excellent hardness and wear properties.

SIZING

“Vee” Ported Seats reduce the valve orifice resulting in a lower flow capacity. The capacity is about half that of a full ported gate valve, very similar to a wye pattern globe valve.

APPLICATIONS

- Above and Below Seat Turbine Drains
- Turbine Case Drains
- Main Steam Drains
- Feedwater Regulating Bypass
- Steam Line Vents

“Vee” Port Seat



“Vee” Port Design

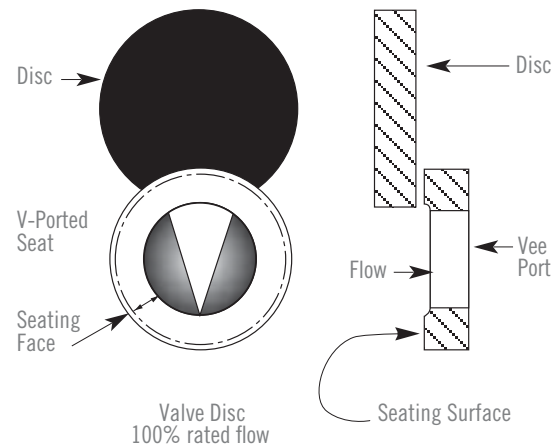

Flow Characteristic of Vee-Port Parallel Slide Gate Valves

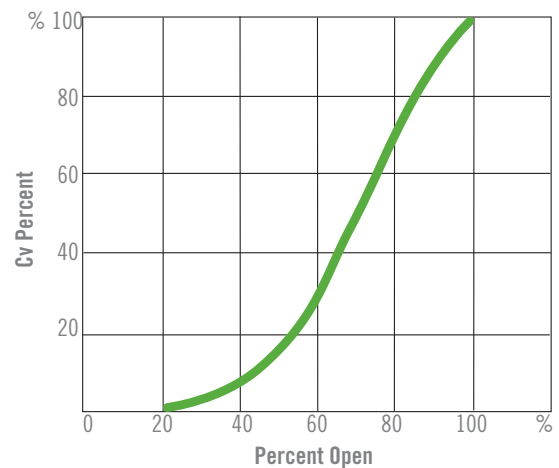

REHEAT ISOLATION DEVICE FOR COLD AND HOT REHEAT LINES

The Atwood & Morrill® Reheat Isolation Device provides a **time saving** method for hydrostatic testing, wet or dry lay up and chemical cleaning. It allows an open pipeline during normal operation, and isolating closure that can be installed in 2 to 3 hours. Whatever your needs, the Atwood & Morrill® Reheat Isolation Device will help prevent any unplanned or undesired shutdowns.

The Reheat Isolation Device allows hydrostatic testing of the reheater to be conducted easily and efficiently. The simple design has many features similar to our Parallel Slide Gate Valve. It offers a **lower weight and less costly** option than either blanking flanges or a conventional stop valve.

CONSTRUCTION

The cast carbon or alloy steel body has two parallel faces inside a center seat area. The turbine end seating face is supplied in stainless steel to prevent corrosion. Access to the Reheat Isolation Device is via a simple bolted bonnet cover. A pressure seal bonnet is also available for higher pressure applications. A spiral wound Flexitallic type, cover gasket is used to provide a tight seal for full system cycles.

OPERATION

During normal operation, the Reheat Isolation Device effectively becomes part of the pipe, offering an unobstructed flow passage with low pressure drop. To meet very low pressure loss requirements, the Reheat Isolation Device can be supplied with a bolt on flow guide.

Before testing, the bonnet cover is removed and the disc closure assembly is lowered into the body. The disc closure assembly consists of a disc with an "O" ring face seal and locking bar. The middle of the locking bar is fitted with an adjusting screw that, when turned clockwise, compresses the "O" ring to provide the initial seal. The test fluid provides additional sealing. Replacing the bonnet cover completely isolates the reheater.

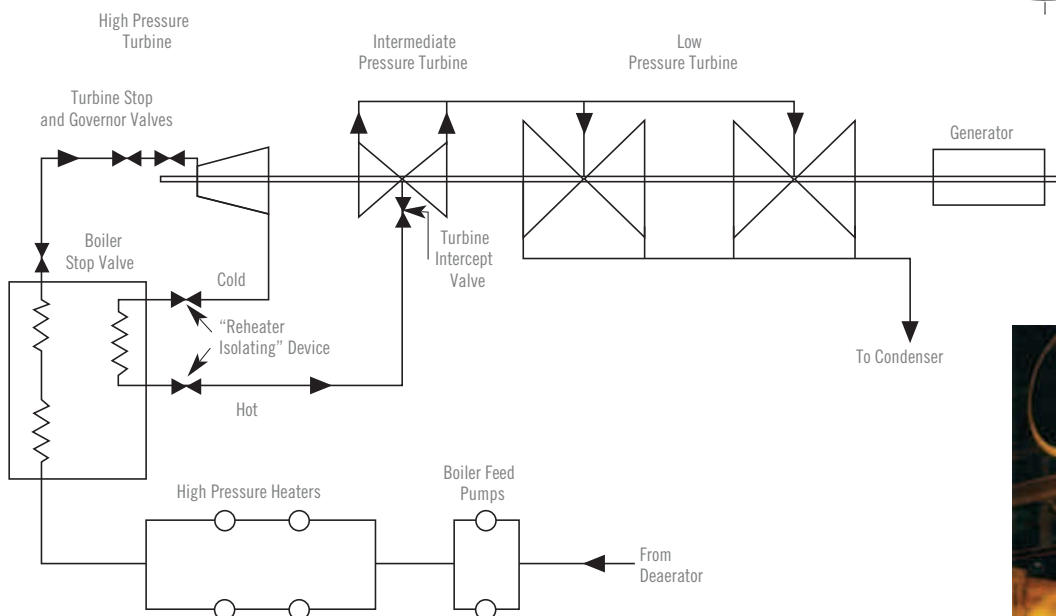
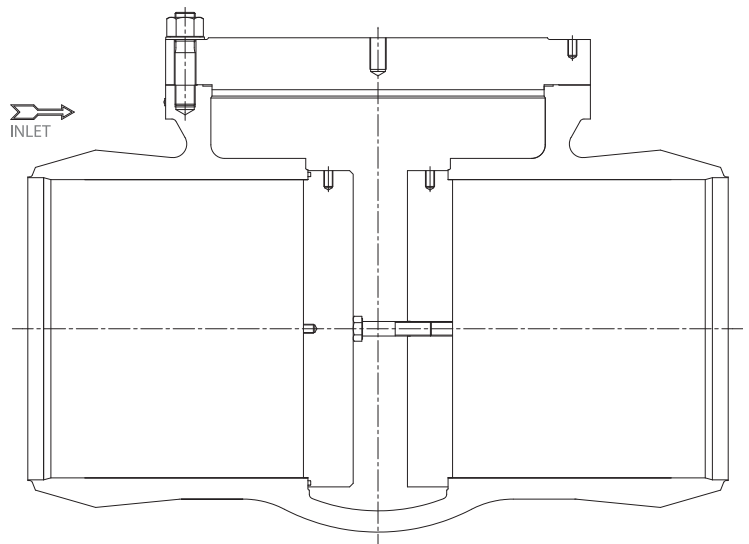

PLANT LAYOUT

Location of Reheat Isolation Device on Cold and Hot Reheat Lines



44" Class 400 Reheat Isolation Device

CONDENSER PROTECTION

Atmospheric Relief Valves are protective devices for emergency service, providing automatic protection for costly turbine and condenser equipment. They should be considered equally as important as Trip Throttle Valves, overspeed governors, and other devices for power plant protection.

The Atwood & Morrill® Atmospheric Relief Valve for condenser service was developed after long experience in manufacturing protective equipment. The finest materials and workmanship assure our customers a completely dependable valve when an emergency occurs.

SPECIFICATIONS

4" through 36" Larger Sizes and Special Designs on application.

MATERIALS

Cast Steel

TRIM MATERIALS

Stainless Steel

SEATING SURFACES

Stainless Steel

BODY STYLE

Globe - Horizontal or Vertical

WATERSEAL

Standard on all sizes

GAUGE GLASS

Available

FEATURES

Materials of Construction

To insure that the valve will function properly, the materials used must resist corrosion over long periods of time. To meet this requirement, Atwood & Morrill® valves use stainless steel trim throughout the valve.

Alignment and Guide of Valve Disc

An important feature is adequate guiding of all moving parts to eliminate binding and insure perfect alignment of all operating parts. Heavy guides are provided both above and below the disc. All discs are machined on centers to assure alignment.

Seating Surfaces

In larger valve sizes, the seat is made up of a screwed stainless steel ring. This surface is machined on centers at the same time the finish chip is taken on the guiding surfaces to assure proper seat-guide alignment.

Waterseal

All valves are provided with a waterseal around the valve disc of ample depth to insure proper sealing of the seat. Supply and overflow connections are provided.

An optional gauge glass can be provided to permit examination of the water level in the waterseal groove.

For valves equipped with bottom lifting devices, the stem stuffing box can also be watersealed.

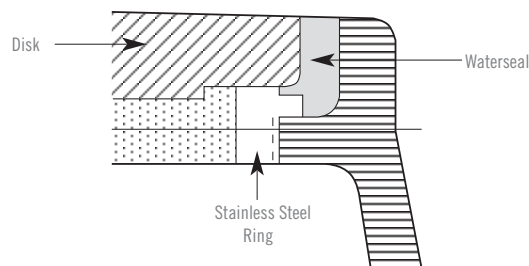

DESCRIPTION

Horizontal Type

Sizes 4" through 36". These valves are equipped with a screw lifting mechanism, top or bottom mounted as required. A bottom hydraulic lifting mechanism is also available.

Vertical Type

Sizes 4" through 36" with side mounted screw lifting mechanisms.

Sizing

To properly safeguard equipment, the valve must be correctly sized. In recommending Atmospheric Relief Valve sizes, we are guided by the Heat Exchange Institute standards: *The size of Atmospheric Relief Valves is dependent upon the local operating conditions. It is always understood that they must be of sufficient size to pass all of the steam which can be admitted to a turbine or engine through any openings, except from the lines which are already protected by relief valves set to open at pressures not exceeding 10# gage. For example, an extraction or bleeder turbine would normally require an Atmospheric Relief Valve of sufficient size to take care of the full throttle steam flow to the condenser under normal operation. The size of Atmospheric Relief Valves for normal operation of condensing turbines should be based on the following criteria for selection:

1. Valve size in associated piping should be selected to prevent pressure in condenser from exceeding 10 psig \pm 10% accumulation.
2. Tolerance or set pressure of relief valve should not exceed \pm 5%.**

Design Features Recommended:

1. Waterseal on valve disc. Provision for adequate drain must be provided to prevent buildup of hydrostatic head on valve disc.
2. Valve shall be equipped with manual lifting or opening device.

When valves are designed for maximum noncondensing operation they must be sized to flow all incoming steam at the design non-condensing pressure. It is suggested that in lieu of an Atmospheric Relief Valve being sized for this flow, a Relief Valve for protection be provided and a separate Gate or Butterfly Valve be provided for additional flow for noncondensing operation.

The sizes listed “for protection” are normally used under ordinary condensing operation and are for general reference only.

If it is desired to operate the turbine temporarily, non-condensing and its maximum non-condensing capacity, the sizes listed under “For Maximum Non-condensing Operation” should be used. Actual design conditions, i.e., flow, relieving pressure, should be established by the user and condenser manufacturer. The valve relieving capacity and design should be certified by the valve supplier.”

*Reprinted from the “STANDARDS FOR DIRECT CONTACT BAROMETRIC AND LOW LEVEL CONDENSERS”. Fourth Edition, Copyright 1970 by the Heat Exchange Institute, 122 East 42nd Street, New York, N.Y. 10017. ** If the disc is spring loaded the tolerance for the set pressure is ± 2 psi.

ATMOSPHERIC RELIEF VALVE SIZES - LOW LEVEL CONDENSERS ONLY

POUNDS OF STEAM PER HOUR			FOR PROTECTION	FOR MAXIMUM NONCONDENSING OPERATION
Up	to	7,500	6"	8"
7,501	to	11,800	8"	10"
11,801	to	17,000	8"	12"
17,001	to	20,000	8"	14"
20,001	to	23,100	10"	14"
23,001	to	30,200	10"	16"
30,201	to	38,200	12"	18"
38,201	to	45,000	12"	20"
45,001	to	47,200	14"	20"
47,201	to	62,000	14"	24"
62,001	to	68,000	16"	24"
68,001	to	82,000	16"	30"
82,001	to	106,000	18"	30"
106,001	to	120,000	18"	—
120,001	to	170,000	20"	—
170,001	to	250,000	24"	—
250,001	to	380,000	30"	—
380,001	to	550,000	36"	—

APPROPRIATE WEIGHTS OF ATMOSPHERIC RELIEF VALVES

VALVE SIZE INCHES	HORIZONTAL*	VERTICAL*
4	115	87
5	140	108
6	190	167
8	350	290
10	520	430
12	725	560
14	950	705
16	1200	1060
18	1500	1360
20	1850	1625
24	2550	2255
30	5200	4200

*In pounds

OPERATION

Atwood & Morrill® Atmospheric Relief Valves are designed to be tight under full vacuum conditions and to open automatically at a pressure slightly above atmospheric. Valves will reseal after opening and remain tight in service. Internally spring loaded valves are available where relief pressures higher than atmospheric are desired.

INSPECTION AND MAINTENANCE

We strongly recommend that Atmospheric Relief Valves be opened at least once every six months, preferably at more frequent intervals, and at any time the unit is down for periodic inspection. We also urge that valves be opened, inspected internally and cleaned, if necessary, during the regular turbine or condenser inspection.

ATMOSPHERIC RELIEF VALVE TOP SCREW LIFT

SIZE	A	B	C	D	E	F	G	H	J	K	Y
4	10	5.75	10.75	9	.9375	9	7.125	8	.75	7.5	.5
5	11.5	6.5	12.25	10	.9375	10.875	8.25	8	.875	8.5	.5
6	14.5	7.5	13.75	11	1	12.5	9.75	8	.875	9.5	.5
8	22	10	16	13.5	1.125	15.5	11.875	8	.875	11.75	.75
10	24	10	19	16	1.8125	19	14.5	12	1	14.25	.75
12	25.5	11.75	22	19	1.25	22	16.75	12	1	17	.75
14	27	13.25	24	21	1.375	25	18.625	12	1.125	21.25	.75
16	32	16	26	23.5	1.4375	27.25	21	16	1.125	21.25	.75
18	35	16.25	28	25	1.5625	30	23.5	16	1.25	25	.75
24	43	20.5	38	32	1.875	39.5	30	20	1.375	29.5	.75
36	61.25	30	53	46	2.75	59.125	44.625	32	1.625	42.75	.75

ATMOSPHERIC RELIEF VALVE BOTTOM SCREW LIFT

SIZE	A	B	C	D	E	F	G	H	J	K
4	9	5.75	10.75	9	.9375	9	7.125	8	.75	7.5
5	11.5	6.5	12.25	10	.9375	10.875	8.25	8	.875	8.5
6	14.5	7.5	13.75	11	1	12.5	9.75	8	.875	9.5
8	22	9.625	16	13.5	1.125	15.5	11.875	8	.875	11.75
10	23	11.75	19	16	1.1875	19	14.5	12	1	14.25
12	25.25	13	22	19	1.25	22	16.75	12	1	17
14	29	15	24	21	1.375	25	18.625	12	1.125	18.75
16	32	16	26	23.5	1.4375	27.25	21	16	1.25	21.25
18	34.75	17	28	25	1.5625	30	23.5	16	1.25	22.34
20	36.75	18.5	32	27.5	1.6875	33	25.875	20	1.25	25
24	43.75	20.75	38	32	1.875	39.5	30	20	1.375	29.5
30	53	27.5	46	38.75	2.125	50	38.25	28	1.375	36
36	63	31.25	53	46	2.375	59.125	44.625	32	1.375	42.75

VERTICAL ATMOSPHERIC RELIEF VALVE

SIZE	A	B	C	D	E	F	G	H	J	K
4	9	10.75	95	.9375	8	.75	7.5	.75	.75	2.0625
5	11	12.25	10	.9375	8	.875	8.5	.8125	.8125	2.0625
6	11.5	13.75	11	1	8	.875	9.5	1.5	1.5	3
8	18.75	16	13.5	1.125	8	.875	11.75	2.25	2.25	3.5625
10	19.5	19	16	1.1875	12	1	14.25	2.5625	2.5625	4.0625
12	21	22	19	1.25	12	1	17	3.125	3.125	5.625
14	25	24	21	1.375	12	1.125	18.75	3.5	.3.5	5.6875
16	26	26	23.5	1.4375	16	1.125	21.25	4.125	4.125	7
18	30	28	25	1.5625	16	1.25	22.75	5	5	8
20	31	32	27.5	1.6875	20	1.25	25	5.5	5.5	8.75
24	37	38	32	1.875	20	1.375	29.5	6	6	10.875
30	45	46	38.75	2.125	28	1.375	36	6.5	6.5	14
36	50	53	46	2.375	332	1.625	42.75	8	8	16.375

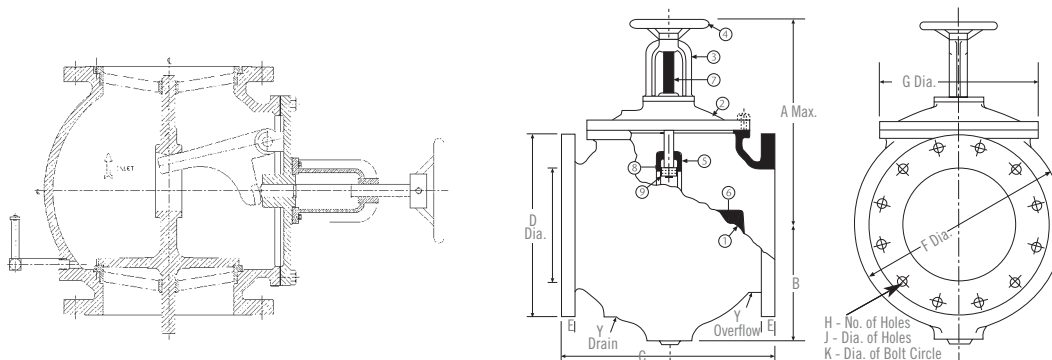

SPRING RELIEF VALVES

The Spring Relief Valve opens at a “set” pressure, gives relief to increasing quantities of steam up to a “full” relief pressure, and reseats without blowdown at approximately the same pressure at which is initially opened.

Our Service Department can repair your existing A&M Spring Relief Valves.

SIZES

6” thru 24” Special Larger Designs on request.

PRESSURE CLASSES

Through Class 300 Rated Flanges
Non Code

BODY STYLE

Globe or Angle Type, Single Seated with external springs.

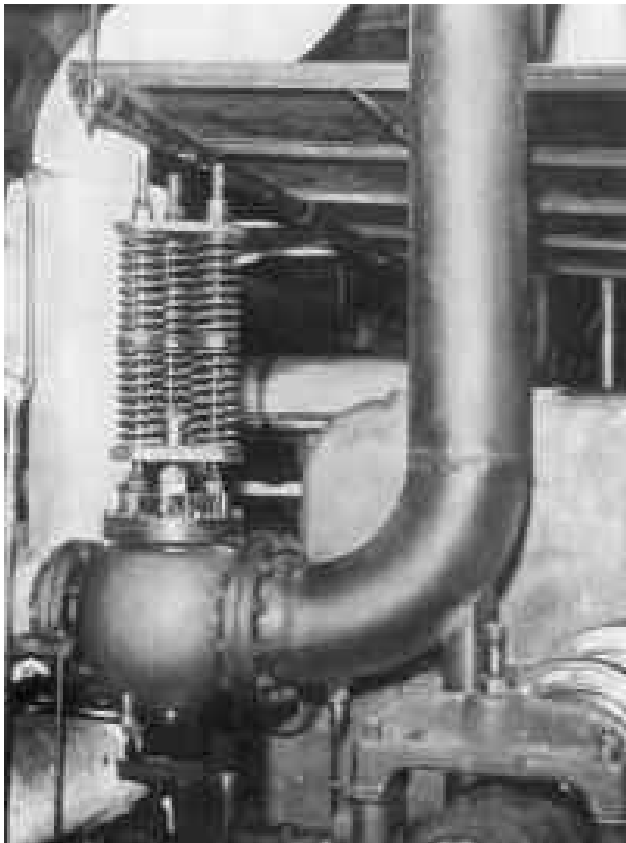
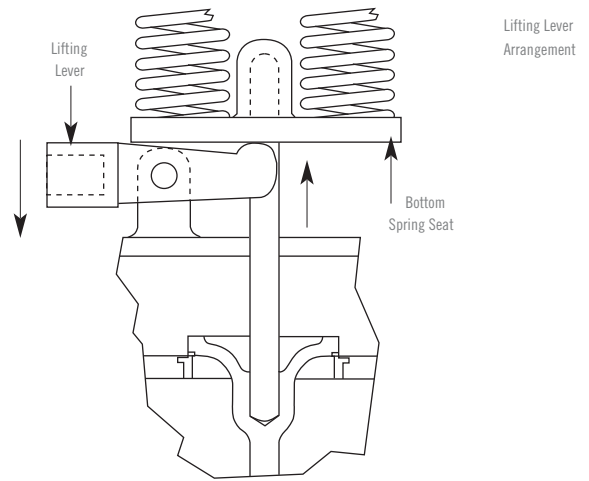



MSIV repair in containment at Nuclear Plant



Through Bonnet Maintenance

UPGRADES, RECOMMENDATIONS AND REPAIRS SERVICE TEAM: ON SITE OR IN HOUSE PARTS DEPARTMENT

Customer Support

- Provides recommended Replacement Parts lists
- Replacement Parts Proposals Price & Delivery
- Identifies Products
- Assists customers with Emergencies

SERVICES

- Operation & Maintenance Manuals
- Technical Bulletins
- Experienced Field Service Engineers
- Outage or Turnaround Valve Repair

SERVICE DEPARTMENT FUNCTIONS

- Provide Technical Support at the customers facility
- Solve Problems and Provide Technical Solutions to problems
- Valve Refurbishment
- Valve Modification and Upgrades

WHEN YOU CALL . . .

We need to know

- Standard Products
- Size, Class & Type Valve
- Model Number
- Serial Number or A&M Order Number
- Parts by Name or Part Number, if known

RECOMMENDATIONS AND REQUIREMENTS

Maintenance, Inspection, Exercising

We recommend a standard program of maintenance, inspection, and exercise for our products. For more information, please refer to the service manual supplied with each valve, or contact your local A&M representative or the home office in Ipswich, Massachusetts.

Installation Recommendations

For longest service life of these or any check valves, installation near sharp bends, elbows, eccentric reducers or expanders or other valves should be avoided. When possible, a length of 10 pipe diameters of straight pipe upstream and 5 pipe diameters of straight pipe downstream is recommended.

Atwood & Morrill® Check Valves are engineered products. It is strongly recommended that a representative or factory sales engineer be consulted before selecting a valve.

RECOMMENDATIONS

We recommend that owners and operators of valves develop an inspection and maintenance program suited to the unique conditions experienced at their plant. The program as a minimum, should require inspection at the first major overhaul and on a regular defined schedule. Valves should be disassembled and inspected for wear or damage.

Damaged parts should be repaired or replaced. Wear patterns should be tracked and logged for future action. Investigate how equipment damage occurred and correct the cause. Unusual events such as, but not limited to plant trips, fires or earthquakes should initiate appropriate inspections. An owner or operator should not assume that any valve is maintenance free.

Implement training programs at your facility to familiarize employees with:

- Safe Valve Operation
- Valve Inspection
- Industrial Safety Hazards
- Proper Maintenance Techniques

For any questions on operation, wear or maintenance, please contact our Service Department.

CONTACT INFORMATION

Our Service Department may be reached at +1-978-744-5690 or atwoodmorrill@trilliumflow.com

ORDERS AND INQUIRIES

When specifying Check Valves, please supply:

1. Flow Conditions: Temperature, Pressure and Flow Rate
2. Style of valve (series or description)
3. Number of valves
4. Service
5. Size or Flow capacity
6. Operating and design temperatures and pressures
7. Special material requirements
8. Maximum allowable pressure drop
9. Pipe run (horizontal or vertical)
10. Mounting of auxiliary equipment (left or right side when facing inlet)
11. Accessory equipment
12. Available air and electrical supply
13. Other pertinent data

VALVE NUMBERING SYSTEM

Family	Sub-group	Design	Size	Pressure	Quality
C	F	F	A	10	S

SAMPLE: CHECK, FREE FLOW, A&M, 10" 600# ISO

Add Options from below checkboxes

PRODUCT FAMILY

B	Butterfly
C	Check
G	Gate
L	Globe
R	Pressure Relief

PRODUCT SUB-GROUP

AG	Angle
AI	Air Pilot
AT	Atmospheric
CP	Compressor
ED	Elbow Down
FF	Free Flow
FW	Feedwater
GE	GE special vlv
GL	Globe
LC	Lift Check
PC	Positive Closing
PO	Pilot Operated
PS	Parallel Slide
SP	Spring Relief
SS	Single Seated
SW	Swing
TE	Testable
TO	Triple Offset
TW	3 Way
WC	Wye Stop Check
WL	Wye Lift Check
WS	Wye Stop
ZZ	Special
IS	Isolation Device

DESIGN

A	A&M
T	Tricentric
H	Hopkinsons

SIZE

OX	1/4"
OY	1/2"
OZ	3/4"
01	1"
1X	1 1/4"
1Y	1 1/2"
1Z	1 3/4"
02	2"
2Y	2 1/2"
03	3"
3Y	3 1/2"
04	4"
05	5"
06	6"
increments of 2	
up to	
98	98"
00	Spec

Class

A	150
B	300
C	400
D	600
E	800
F	900
G	1000
H	1500
J	1700
K	2500
L	3100
M	3600
X	Spec

QUALITY SYSTEM

A	ASME
S	ISO
P	PED
R	IBR

OPTIONS

VALVE MATERIAL

<input type="checkbox"/>	A105
<input type="checkbox"/>	A F11
<input type="checkbox"/>	A F22
<input type="checkbox"/>	A216 WCB
<input type="checkbox"/>	A216 WCC
<input type="checkbox"/>	A217 WC6
<input type="checkbox"/>	A217 WC9
<input type="checkbox"/>	A217 C12A
<input type="checkbox"/>	SA105
<input type="checkbox"/>	SA F11
<input type="checkbox"/>	SA F22
<input type="checkbox"/>	SA216 WCB
<input type="checkbox"/>	SA216 WCC
<input type="checkbox"/>	SA216 WC6
<input type="checkbox"/>	SA216 WC9
<input type="checkbox"/>	SA216 C12A
<input type="checkbox"/>	SA217 WC6
<input type="checkbox"/>	SA217 WC9
<input type="checkbox"/>	SA217 C12A
<input type="checkbox"/>	A182 F11
<input type="checkbox"/>	A182 F22
<input type="checkbox"/>	A351 CF3M
<input type="checkbox"/>	A351 CF8M
<input type="checkbox"/>	SA351 CF8M
<input type="checkbox"/>	A352 LCB
<input type="checkbox"/>	SA352 LCB
<input type="checkbox"/>	Non-standard

OPTIONS (continued)

END CONFIGURATION

<input type="checkbox"/>	Butt Weld
<input type="checkbox"/>	Flanged
<input type="checkbox"/>	Special Ends
<input type="checkbox"/>	Socket Weld

SEAT MATERIAL

<input type="checkbox"/>	No overlay
<input type="checkbox"/>	Alloy 6
<input type="checkbox"/>	Alloy 21
<input type="checkbox"/>	300 Series SST
<input type="checkbox"/>	400 Series SST
<input type="checkbox"/>	Platnam

ACTUATOR

<input type="checkbox"/>	No actuator
<input type="checkbox"/>	Air Cylinder (FFRCV)
<input type="checkbox"/>	Pneumatic
<input type="checkbox"/>	Gear
<input type="checkbox"/>	Handwheel
<input type="checkbox"/>	Hydraulic
<input type="checkbox"/>	Motor
<input type="checkbox"/>	Oil Cylinder (FFRCV)
<input type="checkbox"/>	Ready to Accept

NUT OPTION (only applicable for RTA gear and motor operated valves)

<input type="checkbox"/>	No stem nut
<input type="checkbox"/>	Customer supplied stem nut
<input type="checkbox"/>	Stem nut and machining

NON-DESTRUCTIVE EXAM

<input type="checkbox"/>	No NDE
<input type="checkbox"/>	100% RT Body, Cover
<input type="checkbox"/>	100% RT Body
<input type="checkbox"/>	100% RT/MT Body, Cover
<input type="checkbox"/>	100% RT/MT Body
<input type="checkbox"/>	100% MT Body, Cover
<input type="checkbox"/>	100% MT Body
<input type="checkbox"/>	B16.34 Special Class
<input type="checkbox"/>	100% MT/PT Mach Surf.
<input type="checkbox"/>	RT of Weld Ends Only
<input type="checkbox"/>	PT Seats
<input type="checkbox"/>	RT Weld Ends, PT Seats
<input type="checkbox"/>	RT Critical Areas/Casting
<input type="checkbox"/>	Special NDE

RT = radiographic test
MT = magnetic particle test
PT = penetrant test

For a complete listing of Valve Products visit www.trilliumflow.com

Email valve inquiries to atwoodmorrill@trilliumflow.com

VALVE TYPE		PRODUCT DESCRIPTION	BRAND
Check		Cold Reheat	ATWOOD & MORRILL®
		Compressor	ATWOOD & MORRILL®
		Dual Plate	ATWOOD & MORRILL®, RED POINT®
		FREE FLOW® Reverse Current (water & steam)	ATWOOD & MORRILL®
		Positive Closing	ATWOOD & MORRILL®
		Reheat Stop	ATWOOD & MORRILL®
		Shelf	ATWOOD & MORRILL®
		Spring loaded feedheater bypass	HOPKINSONS®
		Swing (water & steam)	ATWOOD & MORRILL®, HOPKINSONS®, RED POINT®
		Testable	ATWOOD & MORRILL®
		Lift Check (T and Wye Pattern)	ATWOOD & MORRILL®, RED POINT®
Quarter Turn	Ball	Two Piece	RED POINT®
		Three Piece	RED POINT®
		Trunnion	RED POINT®
	Butterfly	Control	BATLEY VALVE®
		Concentric	RED POINT®
		Double Offset / High Performance	RED POINT®
		Triple Offset	TRICENTRIC®
		Turbine Accessory Valves	ATWOOD & MORRILL®, BATLEY VALVE®
	Plug	PTFE Sleeved or Lubricated	RED POINT®
	Multi-Turn	Gate	Knife
Main Steam Isolation Valve			ATWOOD & MORRILL®, HOPKINSONS®
Parallel Slide			ATWOOD & MORRILL®, HOPKINSONS®
Rotary (subsea)			BATLEY VALVE®
Wedge			HOPKINSONS®, RED POINT®
Globe		Drain	HOPKINSONS®, RED POINT®
		Main Steam Isolation Valve	ATWOOD & MORRILL®
		Stop	ATWOOD & MORRILL®
		Stop Check (T and Wye Pattern)	HOPKINSONS®, RED POINT®
		3 Way Bypass	ATWOOD & MORRILL®, HOPKINSONS®
		Air Operated Stop Check	ATWOOD & MORRILL®
		Air Pilot / CO ₂ valve	ATWOOD & MORRILL®
Diaphragm		Diaphragm	RED POINT®
Pressure Relief	Control	Desuperheater	BATLEY VALVE®
		Globe & Angle	BATLEY VALVE®
		Severe Service X-Stream	BATLEY VALVE®
		Steam Conditioning / Turbine Bypass	BATLEY VALVE®
	Safety Relief and Pilot Operated	Atmospheric	ATWOOD & MORRILL®, SARASIN-RSBD®
		Change-over	SARASIN-RSBD®
		Pilot Operated	SARASIN-RSBD®
		Spring Loaded	SARASIN-RSBD®
		Single and Compact Integrated	SEBIM®
		Tandem Relief	SEBIM®

- CHEMICAL PROCESSING • COAL FIRED POWER • COMBINED CYCLE POWER • GENERAL • INDUSTRIAL • FOOD & BEVERAGE •
- LIFE SCIENCES • MARINE • MILITARY • MINING • MUNICIPAL • NUCLEAR POWER • OIL & GAS • PETROCHEM •
- PULP & PAPER • REFINING •

Consult Trillium Salesperson or Agent regarding the most appropriate valve for your specific application. Trillium Brands are registered trademarks of the respective manufacturing locations.



Trillium Valves USA™

29 Old Right Road
Ipswich, Massachusetts 01938 USA
P: +1 978 744 5690
F: +1 978 741 3626
atwoodmorrill@trilliumflow.com

[TRILLIUMFLOW.COM](https://trilliumflow.com)